

Pressure Regulators

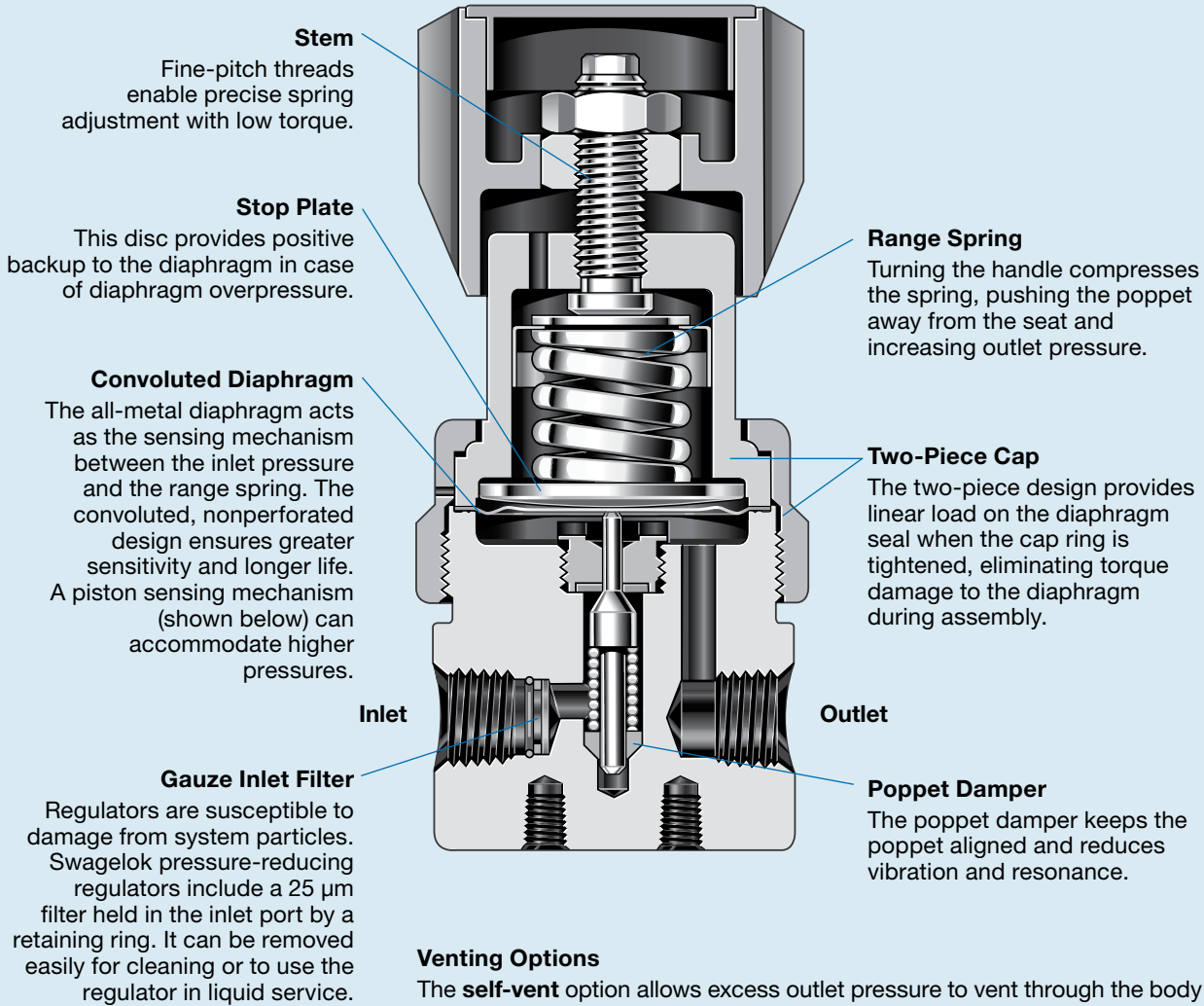

- Pressure-reducing models
- Back-pressure models
- Gas cylinder changeover model
- Vaporizing models

Swagelok® Pressure Regulator Features



Venting Options

The **self-vent** option allows excess outlet pressure to vent through the body cap. This can occur when downstream flow is suddenly reduced or when the handle is adjusted to a lower pressure with little or no flow downstream.

The **captured-vent** option includes a 1/8 in. female NPT connection and stem seal in the body cap^① to allow monitoring of the diaphragm or piston sensing mechanism. It also allows containment of hazardous gas or liquid media should a diaphragm or piston rupture.

Self-vent and captured-vent options can be ordered together so that hazardous gas or liquid media can be contained if vented.

^① The captured-vent port is in the bottom of the KHR series body.

Retaining Ring



Filter

Filter Ring

Piston Sensing Mechanism

Piston sensing mechanisms typically are used to regulate higher pressures than a diaphragm can withstand. They are also more resistant to damage caused by pressure spikes and have a short stroke to maximize cycle life.

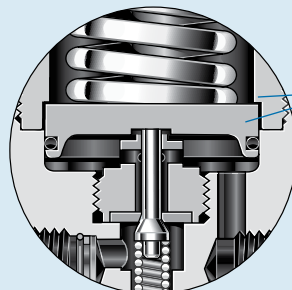

Fully-Contained Piston

The piston is contained by a shoulder in the regulator body cap to prevent piston blowout if the regulator outlet is overpressurized.

Pressure Regulator Operation

Regulators reduce the pressure of a gas or liquid from a source, such as a cylinder or compressor, to a lower value needed by a device, such as an analyzer. A pressure regulator provides better resolution and control when its inlet and control range pressures closely match the pressure requirements of the fluid handling system. *Resolution* is the number of handle turns needed to adjust a regulator from its lowest to highest outlet pressure setting. *Control* is the ability of the regulator to hold a given outlet pressure set point.

Pressure-Reducing Regulators

Pressure-reducing regulators control outlet pressure by balancing an adjustable spring force against the forces caused by inlet and outlet pressures. The spring force is adjusted by turning the stem/handle, which sets the desired outlet pressure.

As inlet pressure decreases, the force balance changes. To compensate, outlet pressure will increase. This supply-pressure effect (SPE) is a function of the design and type of regulator. If a regulator is subjected to fluctuating inlet pressure, and outlet pressure variations are not desirable, a two-stage regulator is available.

Specialty Pressure-Reducing Regulators

Gas Cylinder Changeover

A two-stage gas cylinder changeover model automatically switches between two sources.

Vaporizing

Vaporization regulators are available with electric and steam heat to vaporize liquid samples or to preheat gas samples.

Pressure Regulator Selection

Series	Diaphragm Sensing	Piston Sensing	2 Stage	Gas Cylinder Changeover	Electrical Vaporizing	Steam Vaporizing	Compact, MPC Platform	Maximum Inlet Pressure psig (bar)	Pressure									
									0 to									
									2 (0.13)	10 (0.68)	25 (1.7)	50 (3.4)	100 (6.8)	250 (17.2)	375 (25.8)	500 (34.4)	750 (51.6)	
										Pressure								
KPR	✓							6000 (413)		✓	✓	✓	✓	✓		✓		
KCY	✓		✓							✓	✓	✓	✓	✓		✓		
KLF	✓							3600 (248)	✓	✓	✓	✓	✓	✓				
KHF	✓										✓	✓	✓	✓				
KCP		✓					✓			✓	✓	✓	✓	✓		✓		
KPP		✓						6000 (413)										
KPF		✓																
KHP		✓						10 000 (689)								✓	✓	
KHR		✓															✓	✓
										Speci								
KCM	✓		✓	✓				3600 (248)		✓	✓	✓	✓	✓		✓		
KSV	✓					✓					✓	✓	✓	✓	✓		✓	
KEV	✓ ^①	✓ ^①			✓						✓	✓	✓	✓	✓		✓	
										Back-f								
KBP	✓							Equal to pressure control range		✓	✓	✓	✓	✓		✓		
KFB	✓										✓	✓	✓	✓	✓			
KCB		✓					✓				✓	✓	✓	✓	✓			
KPB		✓																
KHB		✓															✓	✓

① Outlet pressures up to 500 psig (34.4 bar) require diaphragm sensing mechanism; outlet pressures above 500 psig (34.4 bar) require piston sensing mechanism.

Back-Pressure Regulators

Back-pressure regulators control inlet pressure by balancing an adjustable spring force against the force of the inlet pressure. The spring force is adjusted by turning the stem/handle, which sets the desired inlet pressure.

When the force caused by the inlet pressure rises above the force of the spring, the regulator opens until the spring force and inlet pressure are balanced again.

⚠ Swagelok pressure regulators are not “Safety Accessories” as defined in the Pressure Equipment Directive 97/23/EC.

⚠ Do not use the regulator as a shutoff device.

Testing

Every Swagelok regulator is pressure tested with nitrogen.

Cleaning and Packaging

Every Swagelok regulator is cleaned and packaged in accordance with Swagelok *Standard Cleaning and Packaging (SC-10)*, MS-06-62.

Cleaning and packaging to ensure compliance with product cleanliness requirements stated in ASTM G93 Level E is available for brass and stainless steel Swagelok regulators.

Cleaning and packaging in accordance with Swagelok *Special Cleaning and Packaging (SC-11)*, MS-06-63, to ensure compliance with product cleanliness requirements stated in ASTM G93 Level C is available for select KPR, KCY, KCP, KBP, and KCB series regulators.

Oxygen Service Hazards

For more information about hazards and risks of oxygen-enriched systems, see the Swagelok *Oxygen System Safety* technical report, MS-06-13.

Control Ranges, psig (bar)											Flow Coefficient (C _v)							Page
1000 (68.9)	1500 (103)	2000 (137)	3000 (206)	3600 (248)	4000 (275)	10 to 1500 (0.68 to 103)	15 to 2500 (1.0 to 172)	25 to 3600 (1.7 to 248)	50 to 6000 (3.5 to 413)	100 to 10 000 (6.8 to 689)	0.02	0.06	0.10	0.20	0.25	0.50	1.0	
-Reducing Models																		
											✓	✓		✓		✓		6
												✓		✓		✓		8
											✓	✓		✓		✓		10
																	✓	12
✓	✓										✓	✓		✓		✓		14
✓	✓	✓	✓	✓							✓	✓						16
✓		✓	✓		✓												✓	18
						✓	✓	✓	✓	✓		✓			✓			20
						✓	✓	✓	✓	✓		✓			✓			22
ality Regulators																		
												✓						34
												✓		✓				36
✓	✓	✓	✓	✓							✓	✓						38
Pressure Models																		
														✓				24
																	✓	26
													✓	✓				28
✓		✓	✓		✓							✓		✓				30
						✓	✓	✓	✓	✓		✓			✓			32

Contents

- Features, 2
- Operation, 3
- Selection, 3
- Testing, 4
- Cleaning and Packaging, 4

Pressure-Reducing



**General-Purpose
(KPR Series), 6**



**Two-Stage
(KCY Series), 8**



**High-Sensitivity
(KLF Series), 10**



**High-Flow,
High-Sensitivity
(KHF Series), 12**



**Compact
(KCP Series), 14**



**Medium- to
High-Pressure
(KPP Series), 16**



**High-Flow
(KPF Series), 18**



**High-Pressure
(KHP Series), 20**



**High-Pressure
Hydraulic
(KHR Series), 22**

Back-Pressure



**General-Purpose
(KBP Series), 24**



**High-Flow,
High-Sensitivity
(KFB Series), 26**



**Compact
(KCB Series), 28**



**Medium- to
High-Pressure
(KPB Series), 30**



**High-Pressure
(KHB Series), 32**

Specialty Pressure-Reducing



**Gas Cylinder
Changeover
(KCM Series), 34**



**Steam-Heated
Vaporizing
(KSV Series), 36**



**Electrically Heated
Vaporizing
(KEV Series), 38**

Flow Data

- Pressure-Reducing Regulators, 41
- Back-Pressure Regulators, 49

Port Configurations, 52

Options and Accessories, 53

Maintenance Kits, 57

General-Purpose Diaphragm-Sensing, Pressure-Reducing Regulators (KPR Series)

The KPR series is a compact regulator with excellent accuracy, sensitivity, and set-point pressure stability.

Features

- Convoluted, nonperforated diaphragm
- Metal-to-metal diaphragm seal
- Low internal volume
- Two-piece cap design provides linear load on the diaphragm seal
- High-flow, dual-gauze type filter positively retained in inlet port

Technical Data

Maximum Inlet Pressure

- 3600 psig (248 bar)
- 6000 psig (413 bar) with PEEK seat

Pressure Control Ranges

- 0 to 10 psig (0.68 bar) through 0 to 500 psig (34.4 bar)

Flow Coefficient (C_v)

- 0.06 and 0.20
See page 41 for flow graphs.
- 0.02 and 0.50 also available

Maximum Operating Temperature

- 176°F (80°C) with PCTFE seat
- 392°F (200°C) with PEEK seat
- 212°F (100°C) with PEEK seat and maximum inlet pressure greater than 3600 psig (248 bar)

Weight

- 2.4 lb (1.1 kg)

Ports

- 1/4 in. female NPT inlet, outlet, and gauge ports (all body materials)
- 1/4 in. tube stub inlet, outlet, and gauge ports (316 SS body material only)
- 1/4 in. VCR® inlet, outlet, and gauge ports (316 SS body material only)



Materials of Construction

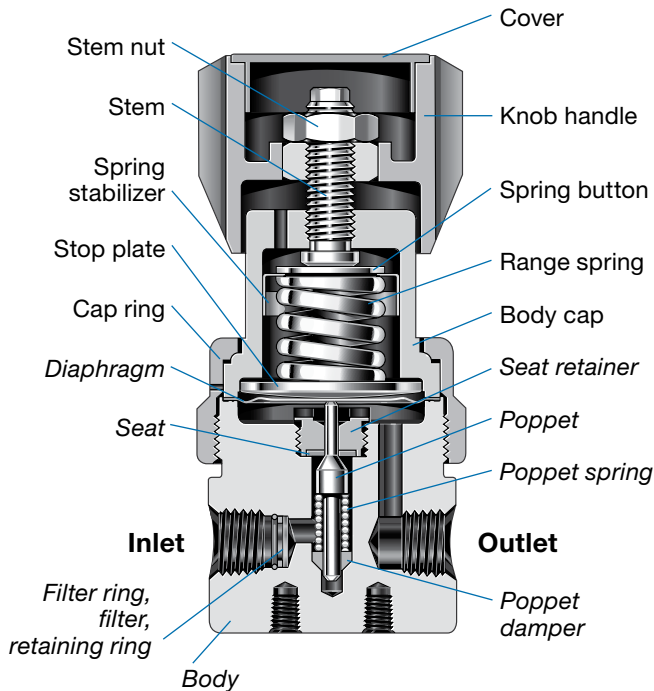

Component	316 SS	Brass CW721R	Alloy 400	Alloy C-276
	Material			
Knob handle, cover	Nylon with 316 SS insert			
Spring button	Zinc-plated steel			
Spring stabilizer ^①	301 SS			
Range spring	316 SS or zinc-plated steel, depending on configuration			
Stem, stem nut, cap ring, stop plate, body cap, panel nuts ^②	316 SS			
VCR nuts ^②	316 SS	—		
Nonwetted lubricant	Hydrocarbon-based			
Seat retainer	316 SS	Alloy 400		Alloy C-276
Seat	PCTFE or PEEK			
Filter, retaining ring	316 SS	Alloy C-22		
Diaphragm ^③	Alloy X-750 or alloy C-276			
Poppet	S17400 SS	Alloy 400		Alloy C-276
Poppet spring	Alloy X-750			Alloy C-276
Poppet damper, filter ring	PTFE			
Self-vent seal ^②	Fluorocarbon FKM		—	
Body	316 SS	Brass CW721R	Alloy 400	Alloy C-276
Tube stub ports, ^② VCR gland ports ^②	316L SS	—		
Wetted lubricant	PTFE-based			

Wetted components listed in *italics*.

① Not required in all configurations.

② Not shown.

③ Regulators with control ranges higher than 0 to 100 psig (0 to 6.8 bar) are assembled with two diaphragms.

Dimensions

Dimensions, in inches (millimeters), are for reference only and are subject to change.

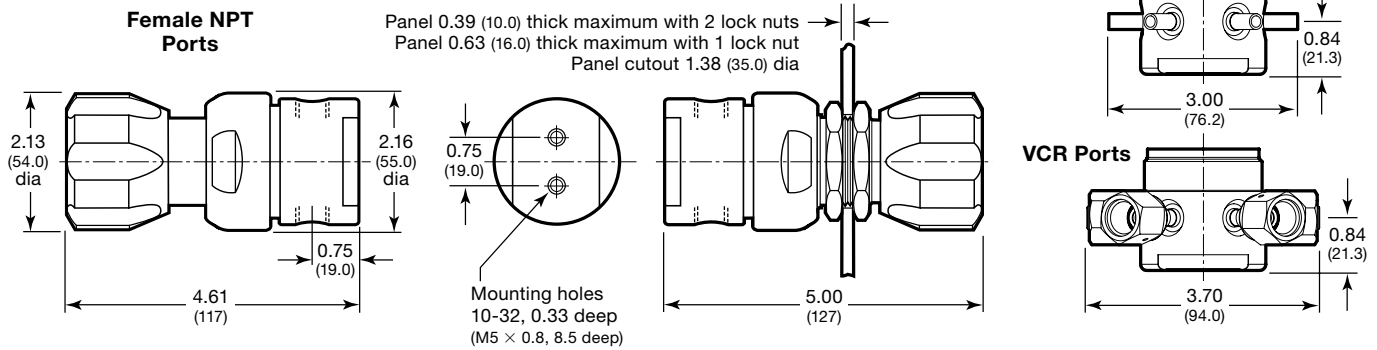

Ordering Information

Build a KPR series regulator ordering number by combining the designators in the sequence shown below.

4 5 6 7 8 9 10 11 12 13 14 15 16
KPR 1 F R F 4 1 2 A 2 0 0 0 0

4 Body Material

- 1 = 316 SS
- 2 = Brass CW721R
- 4 = Alloy 400
- 5 = Alloy C-276
- A = 316 SS, ASTM G93 Level E-cleaned
- B = Brass, ASTM G93 Level E-cleaned
- C = 316 SS, SC-11-cleaned
- D = Brass, SC-11-cleaned

5 Pressure Control Range

- C = 0 to 10 psig (0 to 0.68 bar)^①
- D = 0 to 25 psig (0 to 1.7 bar)^①
- E = 0 to 50 psig (0 to 3.4 bar)
- F = 0 to 100 psig (0 to 6.8 bar)
- G = 0 to 250 psig (0 to 17.2 bar)
- J = 0 to 500 psig (0 to 34.4 bar)

① Not available with maximum inlet pressure greater than 3600 psig (248 bar). Not available with flow coefficient greater than 0.06.

6 Maximum Inlet Pressure^①

- F = 100 psig (6.8 bar)
- J = 500 psig (34.4 bar)
- L = 1000 psig (68.9 bar)
- P = 3000 psig (206 bar)^②
- R = 3600 psig (248 bar)^③
- T = 4351 psig (300 bar)^{③④}
- W = 6000 psig (413 bar)^{③④⑤}

- ① For better resolution and control, select a pressure that closely matches system pressure.
- ② Available for regulators assembled with CGA cylinder connection or inlet hose only.
- ③ Not available for regulators assembled with CGA cylinder connection or inlet hose.
- ④ Available only with 316 SS body material and PEEK seat material. Not available with SC-11 cleaning.
- ⑤ Not available for regulators assembled with isolation valves.

7 Port Configuration

A, B, C, E, F, H, K, L, M, N

See **Port Configurations**, page 52.

8 Ports

- 4 = 1/4 in. female NPT
- T = 1/4 in. × 0.035 in. tube stub^①
- V = 1/4 in. VCR gland, no nuts^{①②}
- X = 1/4 in. rotatable female VCR fitting^①
- Y = 1/4 in. rotatable male VCR fitting^①

① Available only with 316 SS body material in A and F port configurations; does not contain a filter. Not available with maximum inlet pressure greater than 3600 psig (248 bar). Not available ASTM G93 Level E-cleaned.

② For use with VCR split-nuts, which can be ordered separately. See the Swagelok *VCR Metal Gasket Face Seal Fittings* catalog, MS-01-24.

9 Seat Material

- 1 = PCTFE
- 2 = PEEK

10 Flow Coefficient (C_v)

- 1 = 0.02 5 = 0.20
- 2 = 0.06 7 = 0.50

11 Sensing Mechanism, Vent

- A = Alloy X-750 diaphragm, no vent
- C = Alloy X-750 diaphragm, self vent^①
- E = Alloy X-750 diaphragm, captured vent, no self vent
- F = Alloy X-750 diaphragm, self and captured vent^①
- H = Alloy C-276 diaphragm, no vent

① Available only with 316 SS and brass body materials and 0.06 and 0.20 C_v.

12 Handle, Mounting

- 2 = Knob
- 3 = 316 SS antitamper nut
- 6 = Knob, panel mount
- 7 = 316 SS antitamper nut, panel mount

For knob handle color options, see page 56.

13 Isolation and Relief Valves

- 0 = No valves

For isolation and relief valve options, see page 54.

14 Cylinder Connections

- 0 = No connections

For CGA cylinder connection options, see page 53.

15 Gauges

- 0 = No gauges

For inlet and outlet gauge options, see page 54.

16 Options

- 0 = No options
- H = Inboard helium leak test to a maximum leak rate of 1×10^{-5} std cm³/s
- 3 = 3 ft, 1/4 in. FM series metal flexible hose, 1/4 in. female NPT inlet^①
- 4 = 3 ft, 1/4 in. TH series PTFE-lined, stainless steel braided hose, 1/4 in. female NPT inlet^①

For more information about hoses, see page 56.

① Hoses are not available for ASTM G93 Level E-cleaned and SC-11 cleaned regulators.

Select KPR series regulators are available that meet the testing requirements of ASTM G175, "Standard Test Method for Evaluating the Ignition Sensitivity and Fault Tolerance of Oxygen Regulators Used for Medical and Emergency Applications." Contact your authorized Swagelok sales and service representative.

Two-Stage Diaphragm-Sensing, Pressure-Reducing Regulators (KCY Series)

The KCY series is designed for use in applications requiring constant outlet pressure even with wide variations in inlet pressure. This two-stage regulator is comparable to two single-stage regulators connected in series. The first stage is factory set to reduce the inlet pressure to 500 psig (34.4 bar). The second stage can be adjusted with the handle to achieve the required outlet pressure.

This two-stage arrangement minimizes the supply-pressure effect caused by fluctuating inlet pressure, such as with a depleting gas cylinder. As inlet pressure drops below the setting of the first stage, the regulator then functions as a single-stage regulator. The first-stage pressure setting can be reduced while monitoring the pressure at the interstage port, but lower flow may result.

Features

- Convoluted, nonperforated diaphragm
- Metal-to-metal diaphragm seal
- Excellent set-point stability
- Supply-pressure effect of approximately 0.01 %
- High-flow, dual-gauze type filter positively retained in inlet port

Technical Data

Maximum Inlet Pressure

- 3600 psig (248 bar)
- 6000 psig (413 bar) with PEEK seat

Pressure Control Ranges

- 0 to 10 psig (0.68 bar) through 0 to 500 psig (34.4 bar)

Flow Coefficient (C_v)

- 0.06 and 0.20
See page 42 for flow graphs.
- 0.50 also available

Maximum Operating Temperature

- 176°F (80°C) with PCTFE seat
- 392°F (200°C) with PEEK seat
- 212°F (100°C) with PEEK seat and maximum inlet pressure greater than 3600 psig (248 bar)

Weight

- 4.2 lb (1.9 kg)

Ports

- 1/4 in. female NPT inlet, outlet, and gauge ports



Materials of Construction

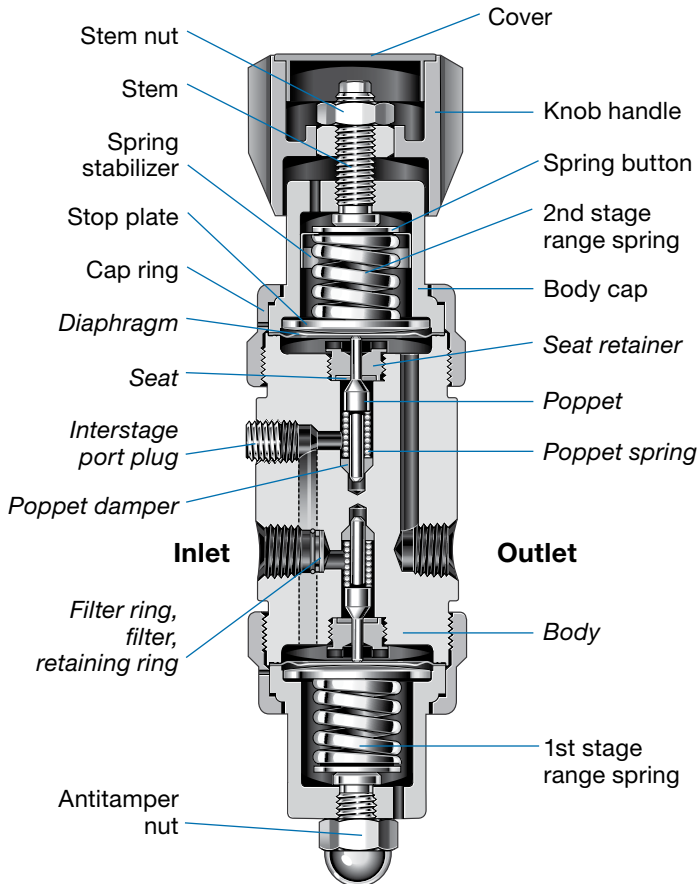

Component	316 SS	Brass CW721R
	Material	
Knob handle, cover	Nylon with 316 SS insert	
Spring buttons	316 SS (1st stage) Zinc-plated steel (2nd stage)	
Spring stabilizer ^①	301 SS	
Range springs	316 SS (0 to 10 through 0 to 100 psig control ranges) ^② Zinc-plated steel (0 to 250 and 0 to 500 psig control ranges)	
Stems, stem nut, cap rings, stop plates, body caps, panel nuts, ^③ antitamper nut	316 SS	
Nonwetted lubricant	Hydrocarbon-based	
Seat retainers, filter, retaining ring	316 SS	
Seats	PCTFE or PEEK	
Diaphragms, ^④ poppet springs	Alloy X-750	
Poppets	S17400 SS	
Poppet dampers, filter ring	PTFE	
Interstage port plug	316 SS with PTFE tape	
Self-vent seal ^③	Fluorocarbon FKM	
Body	316 SS	Brass CW721R
Wetted lubricant	PTFE-based	

Wetted components listed in *italics*.

① Not required in all configurations.

② Regulators with control range 0 to 100 psig (0 to 6.8 bar) and 0.20 C_v have zinc-plated steel range spring.

③ Not shown.

④ Regulators with control ranges higher than 0 to 100 psig (0 to 6.8 bar) are assembled with two diaphragms.

Dimensions

Dimensions, in inches (millimeters), are for reference only and are subject to change.

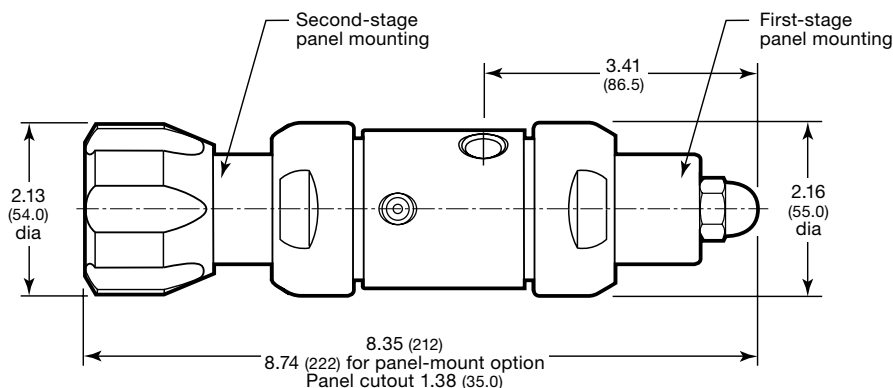

Ordering Information

Build a KCY series regulator ordering number by combining the designators in the sequence shown below.

4 5 6 7 8 9 10 11 12 13 14 15 16
KCY 1 F R F 4 1 2 A 2 0 0 0 0

4 Body Material

- 1 = 316 SS
- 2 = Brass CW721R
- A = 316 SS, ASTM G93 Level E-cleaned
- B = Brass, ASTM G93 Level E-cleaned
- C = 316 SS, SC-11-cleaned
- D = Brass, SC-11-cleaned

5 Pressure Control Range

- C = 0 to 10 psig (0 to 0.68 bar)^①
- D = 0 to 25 psig (0 to 1.7 bar)^①
- E = 0 to 50 psig (0 to 3.4 bar)
- F = 0 to 100 psig (0 to 6.8 bar)
- G = 0 to 250 psig (0 to 17.2 bar)
- J = 0 to 500 psig (0 to 34.4 bar)

^① Not available with maximum inlet pressure greater than 3600 psig (248 bar). Not available with flow coefficient greater than 0.06.

6 Maximum Inlet Pressure

- P = 3000 psig (206 bar)^①
- R = 3600 psig (248 bar)^②
- T = 4351 psig (300 bar)^{②③}
- W = 6000 psig (413 bar)^{②③④}

^① Available for regulators assembled with CGA cylinder connection or inlet hose only.

^② Not available for regulators assembled with CGA cylinder connection or inlet hose.

^③ Available only with 316 SS body material and PEEK seat material. Not available with SC-11 cleaning.

^④ Not available for regulators assembled with isolation valves.

7 Port Configuration

A, B, C, E, F, H, K, L, M, N

See **Port Configurations**, page 52.

8 Ports

- 4 = 1/4 in. female NPT

9 Seat Material

- 1 = PCTFE
- 2 = PEEK

10 Flow Coefficient (C_v)

- 2 = 0.06
- 5 = 0.20
- 7 = 0.50

11 Sensing Mechanism, Vent

- A = Alloy X-750 diaphragm, no vent
- C = Alloy X-750 diaphragm, self vent^①
- E = Alloy X-750 diaphragm, captured vent, no self vent
- F = Alloy X-750 diaphragm, self and captured vent^①

^① Available with 0.06 and 0.2 C_v only. Self vent through second stage only.

12 Handle, Mounting^①

- 2 = Knob
- 3 = Antitamper nut
- 6 = Knob, second-stage panel mount
- 7 = Antitamper nut, second-stage panel mount
- 9 = Knob, first-stage panel mount

For knob handle color options, see page 56.

^① First stage assembled with antitamper nut.

13 Isolation and Relief Valves

- 0 = No valves
- For isolation and relief valve options, see page 54.

14 Cylinder Connections

- 0 = No connections
- For CGA cylinder connection options, see page 53.

15 Gauges

- 0 = No gauges
- For inlet and outlet gauge options, see page 54.

16 Options

- 0 = No options
- 3 = 3 ft, 1/4 in. FM series metal flexible hose, 1/4 in. female NPT inlet^①
- 4 = 3 ft, 1/4 in. TH series PTFE-lined, stainless steel braided hose, 1/4 in. female NPT inlet^①

For more information about hoses, see page 56.

^① Hoses are not available for ASTM G93 Level E-cleaned and SC-11 cleaned regulators.

Select KCY series regulators are available that meet the testing requirements of ASTM G175, "Standard Test Method for Evaluating the Ignition Sensitivity and Fault Tolerance of Oxygen Regulators Used for Medical and Emergency Applications." Contact your authorized Swagelok representative.

High-Sensitivity Diaphragm-Sensing, Pressure-Reducing Regulators (KLF Series)

The KLF series provides high-sensitivity pressure control of gases or liquids with minimum droop in both low-flow and low-pressure applications.

Features

- Large-diameter convoluted, nonperforated diaphragm for increased pressure sensitivity
- Metal-to-metal diaphragm seal
- High-flow, dual-gauze type filter positively retained in inlet port

Technical Data

Maximum Inlet Pressure

- 3600 psig (248 bar)

Pressure Control Ranges

- 0 to 2.0 psig (0.13 bar) through 0 to 250 psig (17.2 bar)

Flow Coefficient (C_v)

- 0.02 and 0.06

See page 43 for flow graphs.

- 0.20 and 0.50 also available

Maximum Operating Temperature

- 176°F (80°C) with PCTFE seat
- 392°F (200°C) with PEEK seat

Weight

- 4.0 lb (1.8 kg)

Ports

- 1/4 in. female NPT inlet, outlet, and gauge ports



Materials of Construction

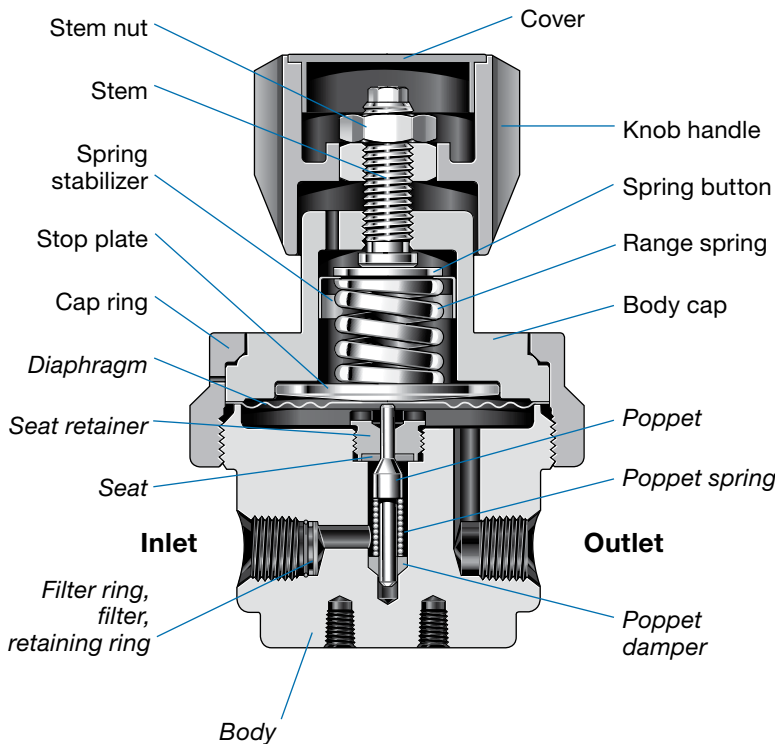

Component	Material
Knob handle, cover	Nylon with 316 SS insert
Spring button	Zinc-plated steel
Spring stabilizer ^①	301 SS
Range spring	316 SS or zinc-plated steel, depending on configuration
Stem, stem nut, cap ring, stop plate, body cap, panel nuts ^②	316 SS
Nonwetted lubricant	Hydrocarbon-based
<i>Body, seat retainer, filter, retaining ring</i>	316 SS
<i>Seat</i>	PCTFE or PEEK
<i>Diaphragm,^③ poppet spring</i>	Alloy X-750
<i>Poppet</i>	S17400 SS
<i>Poppet damper, filter ring</i>	PTFE
<i>Wetted lubricant</i>	PTFE-based

Wetted components listed in *italics*.

① Not required in all configurations.

② Not shown.

③ Regulators with control range 0 to 250 psig (0 to 17.2 bar) are assembled with two diaphragms.

Dimensions

Dimensions, in inches (millimeters), are for reference only and are subject to change.

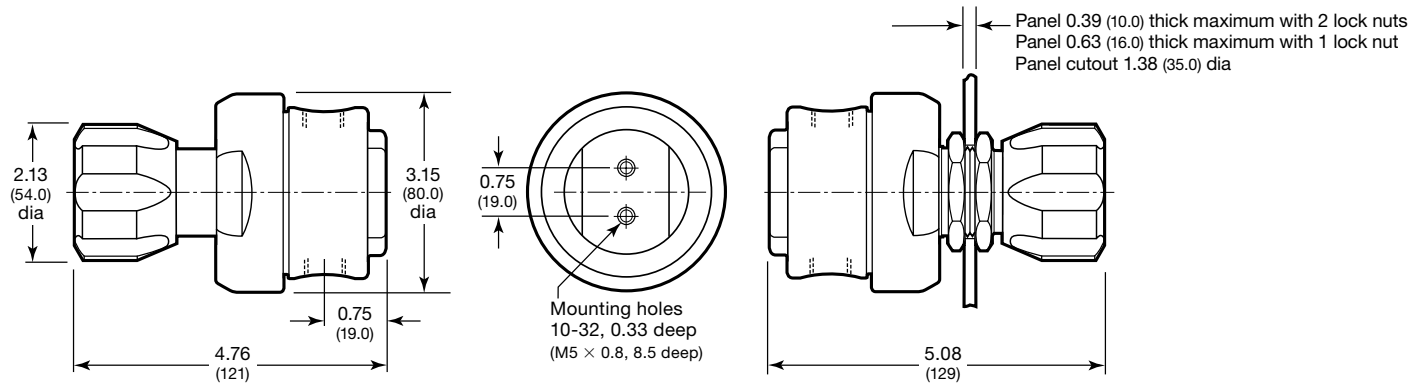

Ordering Information

Build a KLF series regulator ordering number by combining the designators in the sequence shown below.

4 5 6 7 8 9 10 11 12 13 14 15 16
KLF 1 B C F 4 1 2 A 2 0 0 0 0

4 Body Material

- 1 = 316 SS
- A = 316 SS, ASTM G93 Level E-cleaned

5 Pressure Control Range

- B = 0 to 2.0 psig (0 to 0.13 bar)^①
- C = 0 to 10 psig (0 to 0.68 bar)
- D = 0 to 25 psig (0 to 1.7 bar)
- E = 0 to 50 psig (0 to 3.4 bar)
- F = 0 to 100 psig (0 to 6.8 bar)
- G = 0 to 250 psig (0 to 17.2 bar)

^① Available with 15 psig (1.0 bar) maximum inlet pressure only.

6 Maximum Inlet Pressure^①

- C = 15 psig (1.0 bar)^②
- F = 100 psig (6.8 bar)
- J = 500 psig (34.4 bar)
- L = 1000 psig (68.9 bar)
- P = 3000 psig (206 bar)^③
- R = 3600 psig (248 bar)^④

^① For better resolution and control, select a pressure that closely matches system pressure.

^② Available with 0 to 2.0 psig (0 to 0.13 bar) pressure control range only.

^③ Available for regulators assembled with CGA cylinder connection or inlet hose only.

^④ Not available for regulators assembled with CGA cylinder connection or inlet hose.

7 Port Configuration

- A, B, C, E, F, H, K, L, M, N
- See **Port Configurations**, page 52.

8 Ports

- 4 = 1/4 in. female NPT

9 Seat Material

- 1 = PCTFE
- 2 = PEEK

10 Flow Coefficient (C_v)

- 1 = 0.02
- 2 = 0.06
- 5 = 0.20
- 7 = 0.50

11 Sensing Mechanism, Vent

- A = Alloy X-750 diaphragm, no vent
- E = Alloy X-750 diaphragm, captured vent, no self vent

12 Handle, Mounting

- 2 = Knob
- 3 = 316 SS antitamper nut
- 6 = Knob, panel mount
- 7 = 316 SS antitamper nut, panel mount

For knob handle color options, see page 56.

13 Isolation and Relief Valves

- 0 = No valves
- For isolation and relief valve options, see page 54.

14 Cylinder Connections

- 0 = No connection
- For CGA cylinder connection options, see page 53.

15 Gauges

- 0 = No gauges
- For inlet and outlet gauge options, see page 54.

16 Options

- 0 = No options
- 3 = 3 ft, 1/4 in. FM series metal flexible hose, 1/4 in. female NPT inlet^①
- 4 = 3 ft, 1/4 in. TH series PTFE-lined, stainless steel braided hose, 1/4 in. female NPT inlet^①

For more information about hoses, see page 56.

^① Hoses are not available for ASTM G93 Level E-cleaned regulators.

High-Flow, High-Sensitivity Diaphragm-Sensing, Pressure-Reducing Regulators (KHF Series)

The KHF series combines the high-flow capabilities—1.0 C_v —of a bulk distribution regulator with the high sensitivity and accuracy of a point-of-use regulator.

Features

- Large-diameter convoluted, nonperforated diaphragm for increased pressure sensitivity
- Metal-to-metal diaphragm seal
- Balanced poppet for supply-pressure effect of approximately 0.2 %
- High-flow dual-gauze type filter positively retained in inlet port

Technical Data

Maximum Inlet Pressure

- 3600 psig (248 bar)

Pressure Control Ranges

- 0 to 10 psig (0.68 bar) through 0 to 250 psig (17.2 bar)

Flow Coefficient (C_v)

- 1.0

See page 44 for flow graphs.

Maximum Operating Temperature

- 176°F (80°C) with PCTFE seat
- 392°F (200°C) with PEEK seat

Weight

- 4.4 lb (2.0 kg)

Ports

- 1/2 in. female NPT inlet and outlet; 1/4 in. female NPT gauge port



Materials of Construction

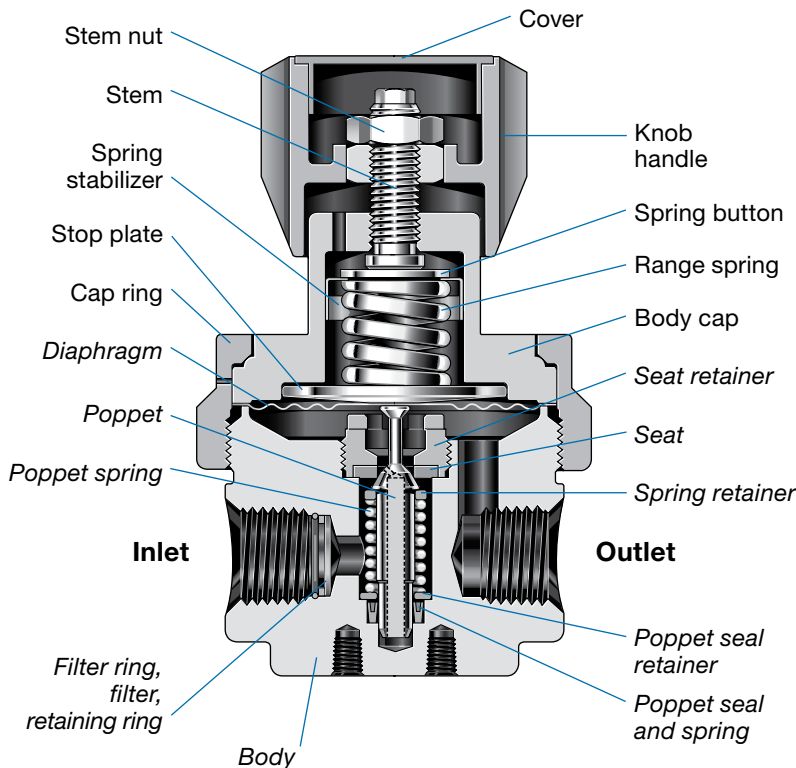

Component	Material
Knob handle, cover	Nylon with 316 SS insert
Spring button	316 SS (0 to 250 psig range) Zinc-plated steel (all other ranges)
Spring stabilizer ^①	301 SS
Range spring	316 SS (0 to 10 and 0 to 25 psig control ranges) Zinc-plated steel (0 to 50 through 0 to 250 psig control ranges)
Stem, stem nut, cap ring, stop plate, body cap, panel nuts ^②	316 SS
Nonwetted lubricant	Hydrocarbon-based
Body, spring retainer, seat retainer, filter, retaining ring, poppet seal retainer	316 SS
Seat	<i>PCTFE or PEEK</i>
Diaphragm ^③	<i>Alloy X-750</i>
Poppet	<i>S17400 SS</i>
Poppet spring	<i>302 SS</i>
Poppet seal, filter ring	<i>PTFE</i>
Poppet seal spring	<i>Elgiloy®</i>
Wetted lubricant	<i>PTFE-based</i>

Wetted components listed in *italics*.

① Not included in regulators with 0 to 250 psig (0 to 17.2 bar) control range.

② Not shown.

③ Regulators with control range 0 to 250 psig (0 to 17.2 bar) are assembled with two diaphragms.

Dimensions

Dimensions, in inches (millimeters), are for reference only and are subject to change.

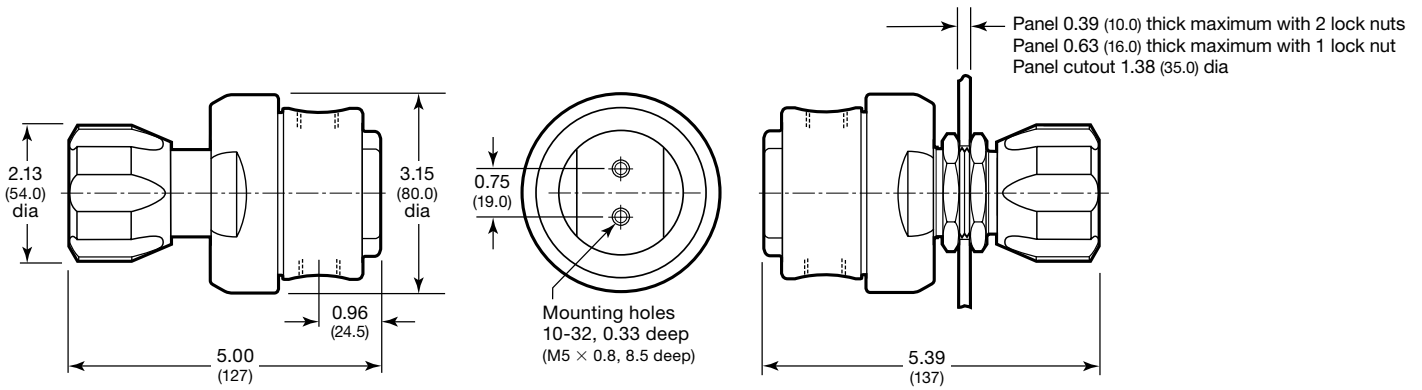

Ordering Information

Build a KHF series regulator ordering number by combining the designators in the sequence shown below.



4 Body Material

- 1 = 316 SS
- A = 316 SS, ASTM G93 Level E-cleaned

5 Pressure Control Range

- C = 0 to 10 psig (0 to 0.68 bar)
- D = 0 to 25 psig (0 to 1.7 bar)
- E = 0 to 50 psig (0 to 3.4 bar)
- F = 0 to 100 psig (0 to 6.8 bar)
- G = 0 to 250 psig (0 to 17.2 bar)

6 Maximum Inlet Pressure^①

- F = 100 psig (6.8 bar)
- J = 500 psig (34.4 bar)
- L = 1000 psig (68.9 bar)
- R = 3600 psig (248 bar)

^① For better resolution and control, select a pressure that closely matches system pressure.

7 Port Configuration

- A, B, C, E, F, H, K, L, M, N
- See **Port Configurations**, page 52.

8 Ports

- 8 = 1/2 in. female NPT inlet and outlet;
1/4 in. female NPT gauge port

9 Seat Material

- 1 = PCTFE
- 2 = PEEK

10 Flow Coefficient (C_v)

- 8 = 1.0

11 Sensing Mechanism, Vent

- A = Alloy X-750 diaphragm, no vent
- E = Alloy X-750 diaphragm, captured vent, no self vent

12 Handle, Mounting

- 2 = Knob
- 3 = 316 SS antitamper nut
- 6 = Knob, panel mount
- 7 = 316 SS antitamper nut, panel mount

For knob handle color options, see page 56.

13 Isolation and Relief Valves

- 0 = No valves
- For isolation and relief valve options, see page 54.

14 Cylinder Connections

- 0 = No connections

15 Gauges

- 0 = No gauges
- For inlet and outlet gauge options, see page 54.

16 Options

- 0 = No options

Compact, Piston-Sensing, Pressure-Reducing Regulators (KCP Series)

The KCP series is a compact, piston-sensing pressure regulator with a short stroke to minimize wear in high-cycling applications.

Features

- Low internal volume
- Fully contained piston
- High-flow, dual-gauze type filter positively retained in inlet port
- ANSI/ISA 76.00.02-compliant modular platform component (MPC) configuration available; MPC platform regulator does not contain a filter

Technical Data

Maximum Inlet Pressure

- 3600 psig (248 bar)

Pressure Control Ranges

- 0 to 10 psig (0.68 bar) through 0 to 1500 psig (103 bar)

Flow Coefficient (C_v)

- 0.06 and 0.20

See page 45 for flow graphs.

- 0.02 and 0.50 also available

Maximum Operating Temperature

- 176°F (80°C) with PCTFE seat
- 392°F (200°C) with PEEK seat

Weight

- 1.0 lb (0.45 kg)

Ports

- 1/8 in. female NPT inlet, outlet, and gauge ports
- MPC platform



Materials of Construction

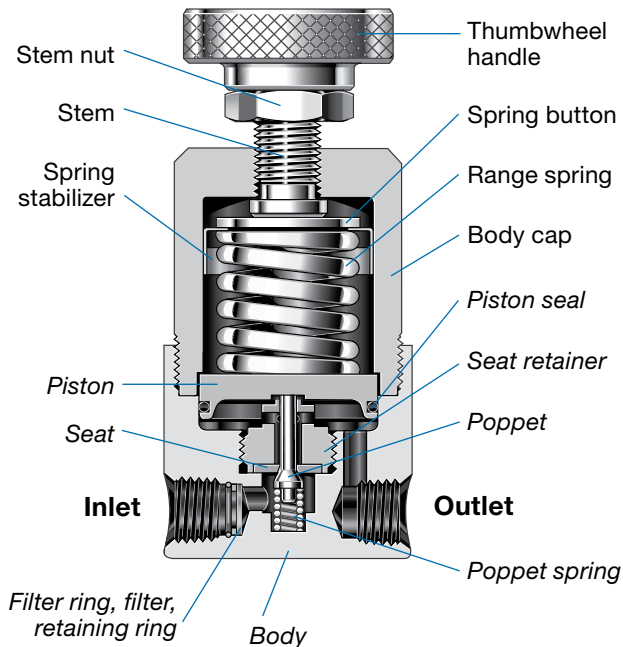

Component	Material
Thumbwheel handle	Anodized aluminum
Knob handle, ^① cover ^①	Nylon with 316 SS insert
Spring button	Zinc-plated steel
Spring stabilizer	301 SS
Range spring	316 SS or zinc-plated steel, depending on configuration
Stem, stem nut, body cap, panel nuts ^①	316 SS
Nonwetted lubricant	Hydrocarbon-based
<i>Body, seat retainer, piston, filter,^② retaining ring^②</i>	316 SS
<i>Piston seal</i>	Fluorocarbon FKM or Kalrez [®]
<i>Seat</i>	PCTFE or PEEK
<i>Poppet</i>	S17400 SS
<i>Poppet spring</i>	302 SS
<i>Filter ring^②</i>	PTFE
<i>Wetted lubricant</i>	PTFE-based

Wetted components listed in italics.

① Not shown.

② MPC platform regulator does not contain a filter.

Dimensions

Dimensions, in inches (millimeters), are for reference only and are subject to change.

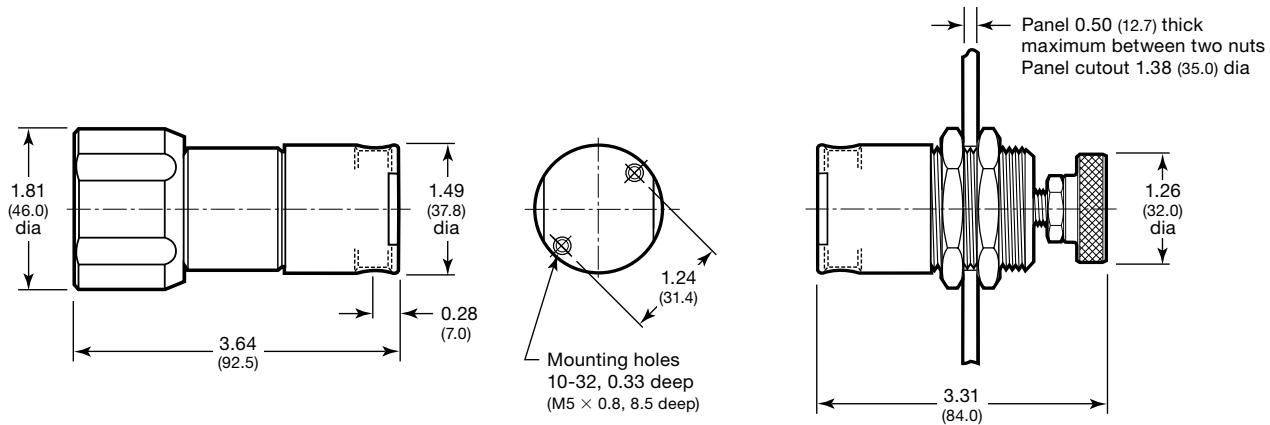

Ordering Information

Build a KCP series regulator ordering number by combining the designators in the sequence shown below.

4 5 6 7 8 9 10 11 12 13 14 15 16
 KCP 1 F R A 2 A 2 P 1 0 0 0 0

4 Body Material

- 1 = 316 SS
- A = 316 SS, ASTM G93 Level E-cleaned
- C = 316 SS, SC-11-cleaned

5 Pressure Control Range

- C = 0 to 10 psig (0 to 0.68 bar)
- D = 0 to 25 psig (0 to 1.7 bar)
- E = 0 to 50 psig (0 to 3.4 bar)
- F = 0 to 100 psig (0 to 6.8 bar)
- G = 0 to 250 psig (0 to 17.2 bar)
- J = 0 to 500 psig (0 to 34.4 bar)
- L = 0 to 1000 psig (0 to 68.9 bar)
- M = 0 to 1500 psig (0 to 103 bar)^①

^① Not available with MPC platform port configuration.

6 Maximum Inlet Pressure^①

- F = 100 psig (6.8 bar)
- J = 500 psig (34.4 bar)
- L = 1000 psig (68.9 bar)
- R = 3600 psig (248 bar)^②

^① For better resolution and control, select a pressure that closely matches system pressure.

^② Not available with MPC platform port configuration.

7 Port Configuration

- A, B, C, E, F, H, K, L, M, N, 5, 6
- See **Port Configurations**, page 52.

8 Ports

- 2 = 1/8 in. female NPT
- M = MPC platform

9 Seat, Seal Material

- A = PCTFE, fluorocarbon FKM
- B = PCTFE, Kalrez
- C = PEEK, fluorocarbon FKM
- D = PEEK, Kalrez

10 Flow Coefficient (C_v)

- 1 = 0.02
- 2 = 0.06
- 5 = 0.20^①
- 7 = 0.50^①

^① Not available with MPC platform port configuration.

11 Sensing Mechanism

- P = 316 SS piston

12 Handle, Mounting

- 1 = Thumbwheel
- 2 = Knob
- 3 = 316 SS antitamper nut
- 5 = Thumbwheel, panel mount
- 6 = Knob, panel mount
- 7 = 316 SS antitamper nut, panel mount

For knob handle color options, see page 56.

13 Isolation Valves

- 0 = No valves

For isolation valve options, see page 54.

14 Cylinder Connections

- 0 = No connections

15 Gauges

- 0 = No gauges

For inlet and outlet gauge options, see page 54.

16 Options

- 0 = No options

Medium- to High-Pressure Piston-Sensing, Pressure-Reducing Regulators (KPP Series)

The KPP series meets the demands of a wide range of gas or liquid applications in a lightweight, compact installation footprint. These features make the KPP pressure regulator an ideal pressure control solution within high-density OEM equipment.

Features

- Lightweight, compact design
- Live-loaded body seals
- Low internal volume
- High-flow, dual-gauze type filter positively retained in inlet port

Technical Data

Maximum Inlet Pressure

- 6000 psig (413 bar)

Pressure Control Ranges

- 0 to 1000 psig (68.9 bar) through 0 to 3600 psig (248 bar)

Flow Coefficient (C_v)

- 0.02 and 0.06

See page 48 for flow graphs.

Maximum Operating Temperature

- 392°F (200°C) with 2000 psig (137 bar) maximum inlet pressure
- 212°F (100°C) with maximum inlet pressure greater than 2000 psig (137 bar)

Weight

- 2.5 lb (1.2 kg)

Ports

- 1/4 in. female NPT inlet, outlet, and gauge ports



Materials of Construction

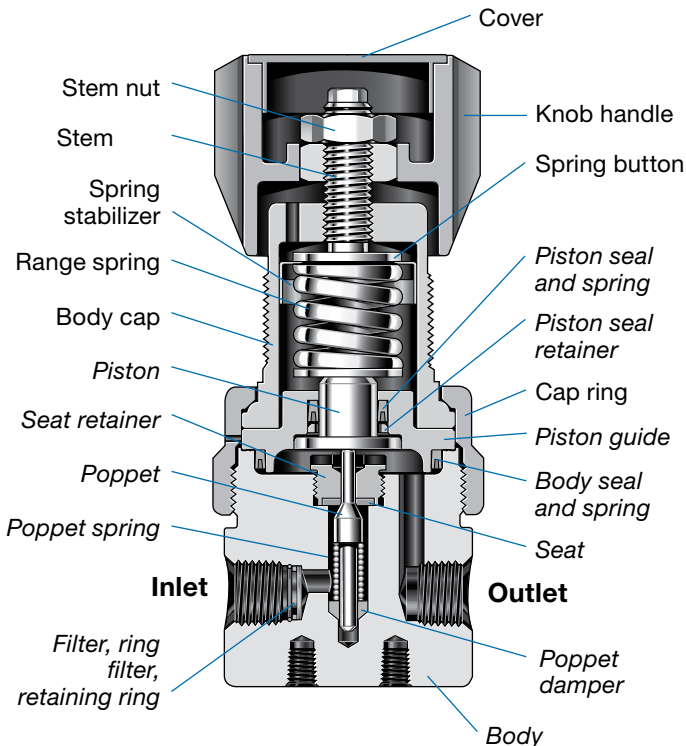

Component	Material
Knob handle, cover	Nylon with 316 SS insert
Spring button	316 SS (0 to 3000 and 0 to 3600 psig range) Zinc-plated steel (all other ranges) ^①
Spring stabilizer ^②	301 SS
Range spring	Zinc-plated steel
Stem, stem nut, cap ring, body cap, panel nuts ^③	316 SS
Nonwetted lubricant	Hydrocarbon-based
<i>Body, seat retainer, filter, retaining ring, piston, piston guide</i>	316 SS
<i>Seat, piston seal retainer</i>	PEEK
<i>Poppet</i>	S17400 SS
<i>Poppet spring</i>	Alloy X-750
<i>Piston seal spring, body seal spring</i>	Elgiloy
<i>Poppet damper, filter ring, piston seal, body seal</i>	PTFE
<i>Wetted lubricant</i>	PTFE-based

Wetted components listed in *italics*.

① 316 SS in regulators with 0 to 2000 psig (0 to 137 bar) control range with 6000 psig (413 bar) inlet pressure and regulators with 0 to 2000 psig (0 to 137 bar) control range, 4000 psig (275 bar) inlet pressure, and 0.06 C_v.

② Not included in regulators with 316 SS spring button.

③ Not shown.

Dimensions

Dimensions, in inches (millimeters), are for reference only and are subject to change.

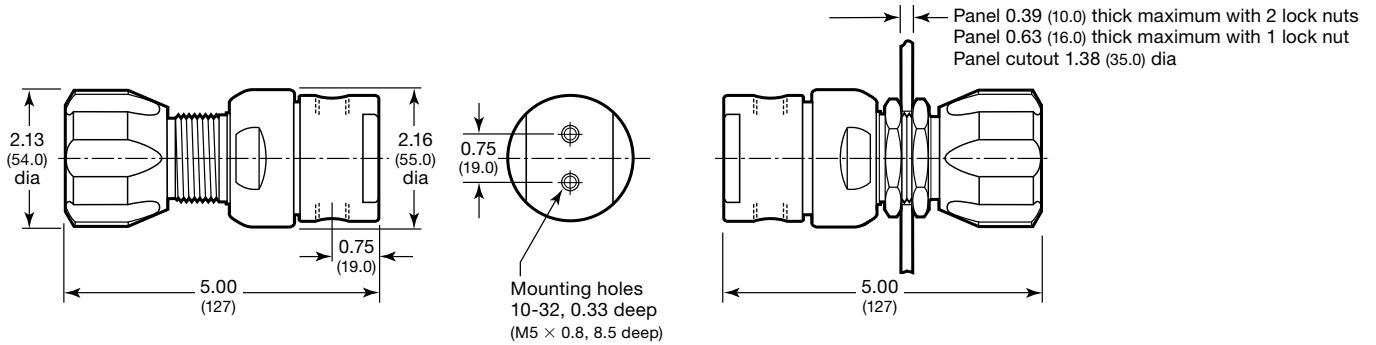

Ordering Information

Build a KPP series regulator ordering number by combining the designators in the sequence shown below.

4 5 6 7 8 9 10 11 12 13 14 15 16
KPP 1 L W A 4 2 2 P 2 0 0 0 0

4 Body Material

- 1 = 316 SS
- A = 316 SS, ASTM G93 Level E-cleaned

5 Pressure Control Range

- L = 0 to 1000 psig (0 to 68.9 bar)
- M = 0 to 1500 psig (0 to 103 bar)
- N = 0 to 2000 psig (0 to 137 bar)
- P = 0 to 3000 psig (0 to 206 bar)^①
- R = 0 to 3600 psig (0 to 248 bar)^①

^① Not available with 2000 psig (137 bar) maximum inlet pressure.

6 Maximum Inlet Pressure^①

- N = 2000 psig (137 bar)
- S = 4000 psig (275 bar)
- W = 6000 psig (413 bar)

^① For better resolution and control, select a pressure that closely matches system pressure.

7 Port Configuration

- A, B, C, E, F, H, K, L, M, N
- See *Port Configurations*, page 52.

8 Ports

- 4 = 1/4 in. female NPT

9 Seat, Seal Material

- 2 = PEEK, PTFE

10 Flow Coefficient (C_v)

- 1 = 0.02
- 2 = 0.06

11 Sensing Mechanism, Vent

- P = 316 SS piston, no vent
- V = 316 SS piston, captured vent, no self vent

12 Handle, Mounting

- 2 = Knob
- 3 = 316 SS antitamper nut
- 6 = Knob, panel mount
- 7 = 316 SS antitamper nut, panel mount
- For knob handle color options, see page 56.

13 Isolation Valves

- 0 = No valves
- For isolation valve options, see page 54.

14 Cylinder Connections

- 0 = No connections

15 Gauges

- 0 = No gauges
- For inlet and outlet gauge options, see page 54.

16 Options

- 0 = No options

High-Flow Piston-Sensing, Pressure-Reducing Regulators (KPF Series)

The KPF series provides minimum droop across the flow range with high accuracy of outlet pressure.

Features

- High flow coefficient ($C_v = 1.0$)
- Balanced poppet for minimal supply-pressure effect
- High-flow, dual-gauze type filter positively retained in inlet port

Technical Data

Maximum Inlet Pressure

- 6000 psig (413 bar)

Pressure Control Ranges

- 0 to 1000 psig (68.9 bar) through 0 to 4000 psig (275 bar)

Flow Coefficient (C_v)

- 1.0

See page 44 for flow graphs.

Maximum Operating Temperature

- 176°F (80°C) with PCTFE seat
- 392°F (200°C) with PEEK seat

Weight

- 4.5 lb (2.1 kg)

Ports

- 1/2 in. female NPT inlet and outlet;
1/4 in. female NPT gauge ports



Materials of Construction

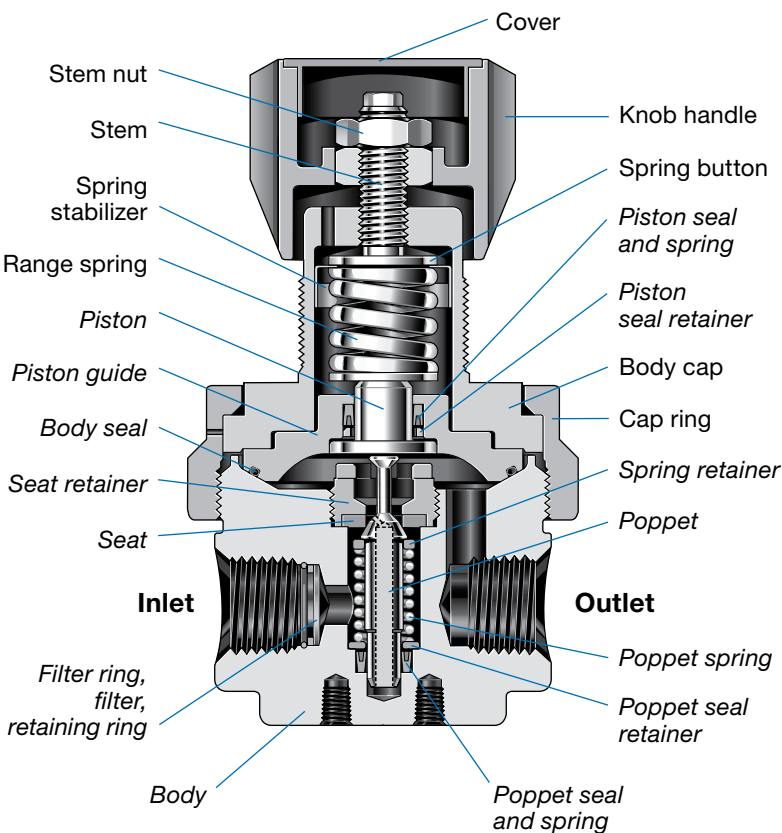

Component	Material
Knob handle, cover	Nylon with 316 SS insert
Spring button	316 SS (0 to 3000 and 0 to 4000 psig range) Zinc-plated steel (all other ranges)
Spring stabilizer ^①	301 SS
Range spring	Zinc-plated steel
Stem, stem nut, cap ring, body cap, panel nuts ^②	316 SS
Nonwetted lubricant	Hydrocarbon-based
<i>Body, spring retainer, seat retainer, filter, retaining ring, piston, piston guide, poppet seal retainer</i>	316 SS
<i>Seat, piston seal retainer</i>	PCTFE or PEEK
<i>Poppet</i>	S17400 SS
<i>Poppet spring</i>	302 SS
<i>Filter ring, piston seal, poppet seal</i>	PTFE
<i>Piston seal spring, poppet seal spring</i>	Elgiloy
<i>Body seal</i>	Fluorocarbon FKM
<i>Wetted lubricant</i>	PTFE-based

Wetted components listed in *italics*.

① Not included in regulators with 316 SS spring button.

② Not shown.

Dimensions

Dimensions, in inches (millimeters), are for reference only and are subject to change.

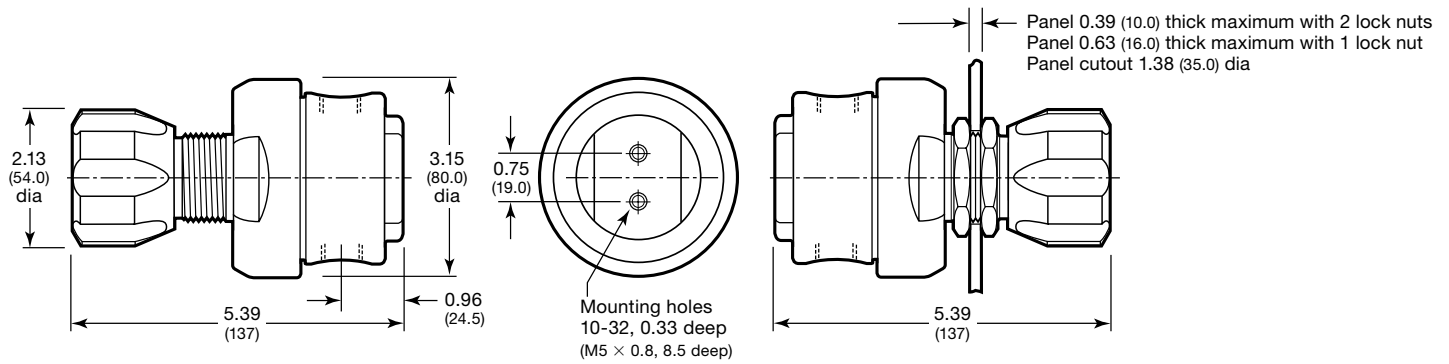

Ordering Information

Build a KPF series regulator ordering number by combining the designators in the sequence shown below.

4 5 6 7 8 9 10 11 12 13 14 15 16
 KPF 1 L W A 8 A 8 P 2 0 0 0 0

4 Body Material

1 = 316 SS
 A = 316 SS, ASTM G93 Level E-cleaned

5 Pressure Control Range

L = 0 to 1000 psig (0 to 68.9 bar)
 N = 0 to 2000 psig (0 to 137 bar)
 P = 0 to 3000 psig (0 to 206 bar)
 S = 0 to 4000 psig (0 to 275 bar)

6 Maximum Inlet Pressure

W = 6000 psig (413 bar)

7 Port Configuration

A, B, C, E, F, H, K, L, M, N

See **Port Configurations**, page 52.

8 Ports

8 = 1/2 in. female NPT inlet and outlet;
 1/4 in. female NPT gauge ports

9 Seat, Body Seal Material

A = PCTFE, fluorocarbon FKM
 C = PEEK, fluorocarbon FKM

10 Flow Coefficient (C_v)

8 = 1.0

11 Sensing Mechanism, Vent

P = 316 SS piston, no vent
 V = 316 SS piston, captured vent, no self vent

12 Handle, Mounting

2 = Knob
 3 = 316 SS antitamper nut
 6 = Knob, panel mount
 7 = 316 SS antitamper nut, panel mount

For knob handle color options, see page 56.

13 Isolation Valves

0 = No valves
 For isolation valve options, see page 54.

14 Cylinder Connections

0 = No connections

15 Gauges

0 = No gauges
 For inlet and outlet gauge options, see page 54.

16 Options

0 = No options

High-Pressure Piston-Sensing, Pressure-Reducing Regulators (KHP Series)

The KHP series provides control of supply pressures up to 10 000 psig (689 bar). The self-venting capability enables downstream pressure reduction in closed-loop systems.

Features

- Thrust roller bearing eases operation
- Panel-mounting configuration available
- High-flow, dual-gauze type filter positively retained in inlet port

Technical Data

Maximum Inlet Pressure

- 10 000 psig (689 bar)

Pressure Control Ranges

- 0 to 500 psig (34.4 bar) through 100 to 10 000 psig (6.8 to 689 bar)

Flow Coefficient (C_v)

- 0.06 and 0.25

See page 46 and 47 for flow graphs.

Maximum Operating Temperature

- 212°F (100°C)

Weight

- 5.7 lb (2.6 kg)

Ports

- 1/4 in. female NPT inlet, outlet, and gauge ports



Materials of Construction

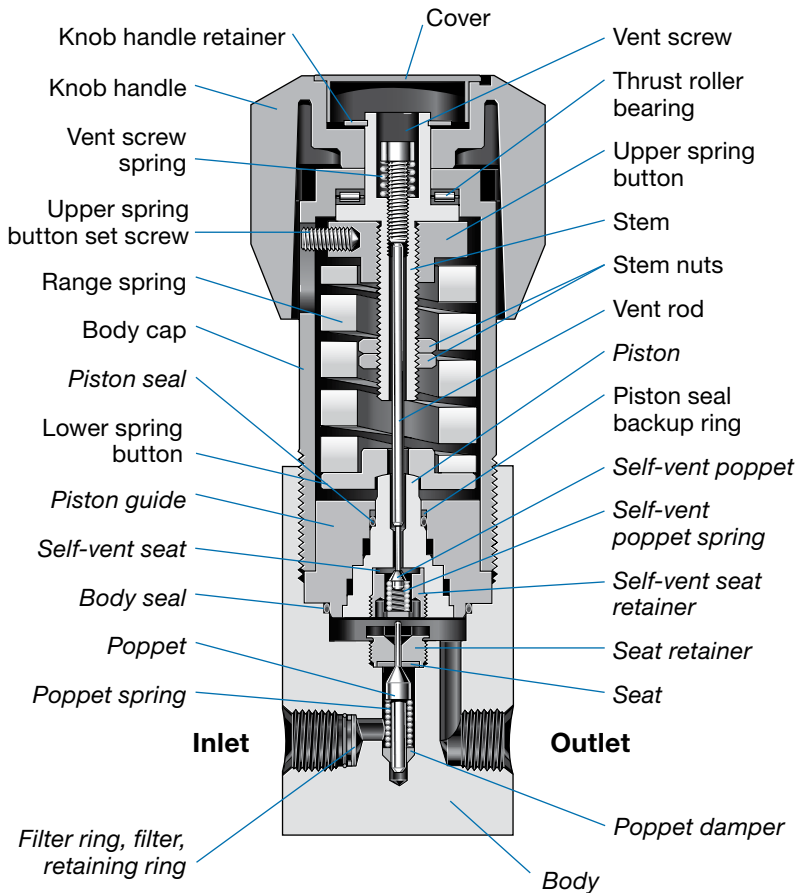

Component	Material
Knob handle, cover	Nylon with 316 SS insert
Spring buttons, upper spring button set screw, knob handle retainer, vent screw, stem nuts, body cap	316 SS
Vent screw spring	302 SS
Vent rod	431 SS
Stem	CZ114 bronze
Thrust roller bearing	Hardened carbon steel
Range spring	Chrome vanadium steel
Piston seal backup ring	PTFE
Nonwetted lubricant	Hydrocarbon-based
<i>Body, seat retainer, filter, retaining ring, piston, piston guide, self-vent seat retainer</i>	316 SS
<i>Seat, self-vent seat</i>	PEEK
<i>Poppet, self-vent poppet</i>	S17400 SS
<i>Poppet spring</i>	Alloy X-750
<i>Poppet damper, filter ring</i>	PTFE
<i>Self-vent poppet spring</i>	302 SS
<i>Body seal, piston seal</i>	Fluorocarbon FKM
<i>Wetted lubricant</i>	PTFE-based

Wetted components listed in italics.

Dimensions

Dimensions, in inches (millimeters), are for reference only and are subject to change.

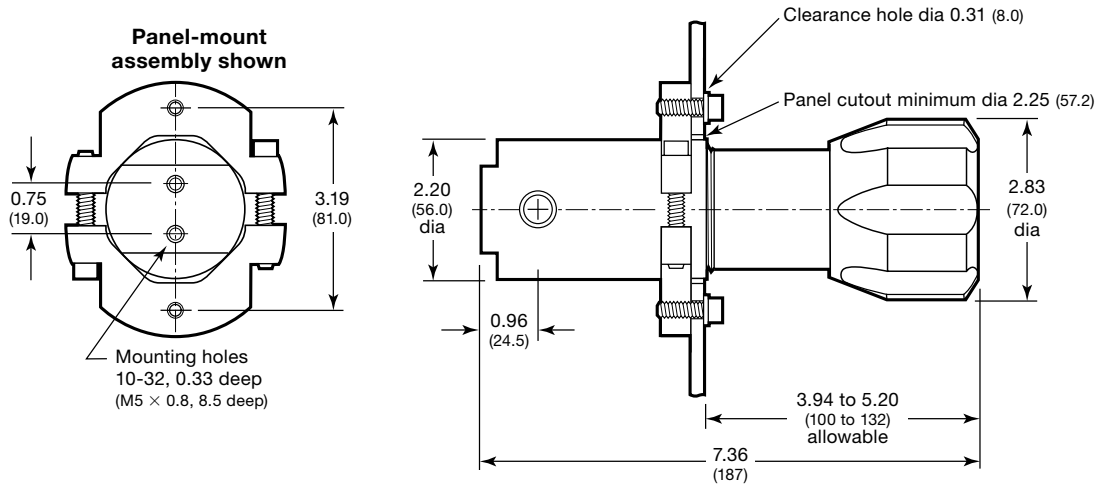

Ordering Information

Build a KHP series regulator ordering number by combining the designators in the sequence shown below.

4 5 6 7 8 9 10 11 12 13 14 15 16
KHP 1 T X A 4 C 2 S 2 0 0 0 0

4 Body Material

1 = 316 SS
 A = 316 SS, ASTM G93 Level E-cleaned

5 Pressure Control Range

J = 0 to 500 psig (0 to 34.4 bar)
 K = 0 to 750 psig (0 to 51.6 bar)
 T = 10 to 1500 psig (0.68 to 103 bar)
 U = 15 to 2500 psig (1.0 to 172 bar)
 V = 25 to 3600 psig (1.7 to 248 bar)
 W = 50 to 6000 psig (3.4 to 413 bar)^①
 X = 100 to 10 000 psig (6.8 to 689 bar)^①

^① Not available for regulators assembled with isolation valves.

6 Maximum Inlet Pressure

X = 10 000 psig (689 bar)

7 Port Configuration

A, B, C, E, F, H, K, L, M, N
 See **Port Configurations**, page 52.

8 Ports

4 = 1/4 in. female NPT

9 Seat, Seal Material

C = PEEK, fluorocarbon FKM

10 Flow Coefficient (C_v)

2 = 0.06
 6 = 0.25

11 Sensing Mechanism, Vent

P = 316 SS piston, no vent
 S = 316 SS piston, self vent

12 Handle, Mounting

2 = Knob
 6 = Knob, panel mount
 For knob handle color options, see page 56.

13 Isolation Valves

0 = No valves
 For isolation valve options, see page 54.

14 Cylinder Connections

0 = No connections

15 Gauges

0 = No gauges
 For inlet and outlet gauge options, see page 54.

16 Options

0 = No options

High-Pressure Piston-Sensing, Hydraulic Pressure-Reducing Regulators (KHR Series)

The KHR series provides control of pressures up to 10 000 psig (689 bar) for both liquid and gas applications. Metal or polymer seats are available.

Features

- Self-venting
- Captured vent port in bottom of body
- Panel-mounting configuration available
- Thrust roller bearing eases operation
- High-flow, dual-gauze type filter positively retained in inlet port

Technical Data

Maximum Inlet Pressure

- 10 000 psig (689 bar)

Pressure Control Ranges

- 0 to 500 psig (34.4 bar) through 100 to 10 000 psig (6.8 to 689 bar)

Flow Coefficient (C_v)

- 0.06

See page 47 for flow graphs.

- 0.25 also available

Maximum Operating Temperature

- 212°F (100°C)

Weight

- 6.1 lb (2.75 kg)

Ports

- 1/4 in. female NPT inlet, outlet, vent, and gauge ports



Materials of Construction

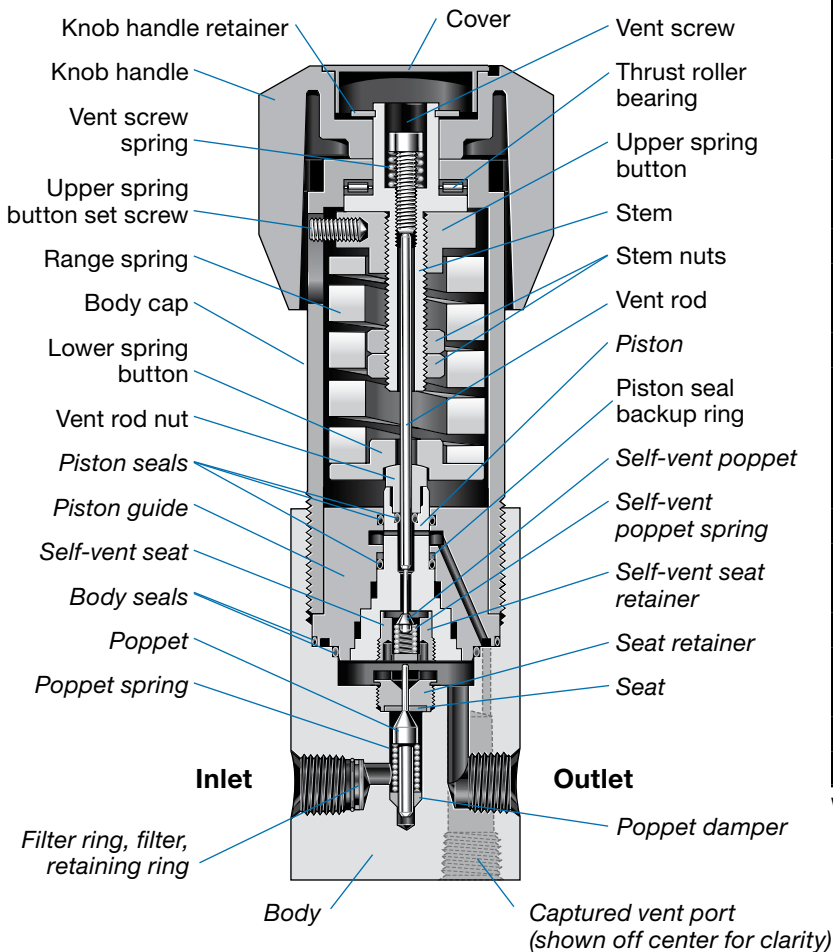

Component	Material
Knob handle, cover	Nylon with 316 SS insert
Spring buttons, upper spring button set screw, knob handle retainer, vent screw, stem nuts, vent rod nut, body cap	316 SS
Vent screw spring	302 SS
Vent rod	431 SS
Stem	CZ114 bronze
Thrust roller bearing	Hardened carbon steel
Range spring	Chrome vanadium steel
Piston seal backup ring	PEEK
Nonwetted lubricant	Hydrocarbon-based
<i>Body, seat retainer, filter, retaining ring, piston, piston guide, self-vent seat retainer</i>	316 SS
<i>Self-vent seat</i>	PEEK
<i>Seat</i>	PEEK or 316 SS
<i>Poppet, self-vent poppet</i>	S17400 SS
<i>Poppet spring</i>	Alloy X-750
<i>Poppet damper, filter ring</i>	PTFE
<i>Self-vent poppet spring</i>	302 SS
<i>Body seals, piston seals</i>	Fluorocarbon FKM
<i>Wetted lubricant</i>	PTFE-based

Wetted components listed in italics.

Dimensions

Dimensions, in inches (millimeters), are for reference only and are subject to change.

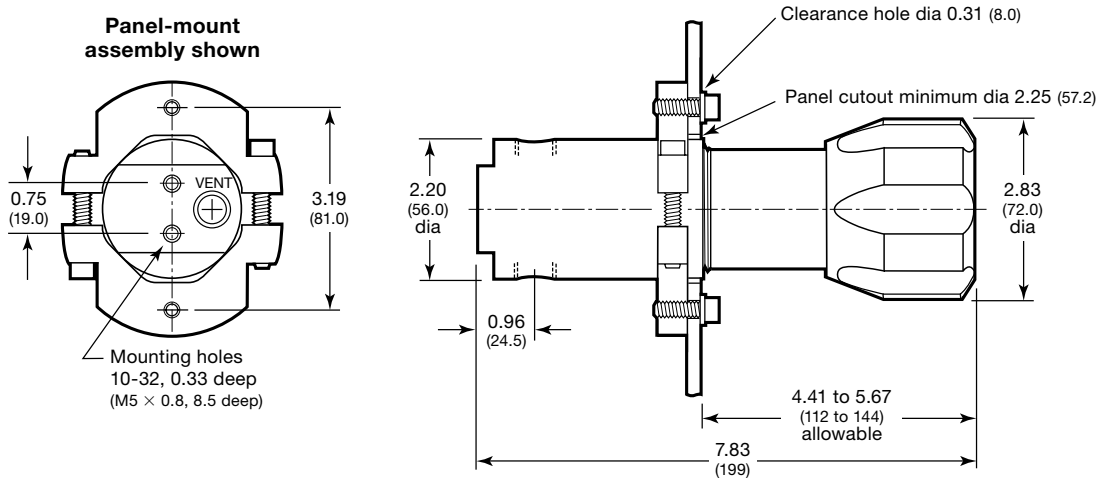

Ordering Information

Build a KHR series regulator ordering number by combining the designators in the sequence shown below.

4 5 6 7 8 9 10 11 12 13 14 15 16
 KHR 1 T X A 4 J 2 U 2 0 0 0 0

4 Body Material

- 1 = 316 SS
- A = 316 SS, ASTM G93 Level E-cleaned

5 Pressure Control Range

- J = 0 to 500 psig (0 to 34.4 bar)
- K = 0 to 750 psig (0 to 51.6 bar)
- T = 10 to 1500 psig (0.68 to 103 bar)
- U = 15 to 2500 psig (1.0 to 172 bar)
- V = 25 to 3600 psig (1.7 to 248 bar)
- W = 50 to 6000 psig (3.4 to 413 bar)^①
- X = 100 to 10 000 psig (6.8 to 689 bar)^①

^① Not available for regulators assembled with isolation valves.

6 Maximum Inlet Pressure

- X = 10 000 psig (689 bar)

7 Port Configuration

- A, B, C, F, M
- See *Port Configurations*, page 52.

8 Ports

- 4 = 1/4 in. female NPT

9 Seat, Seal Material

- C = PEEK, fluorocarbon FKM
- J = 316 SS, fluorocarbon FKM^①

^① Not suitable for gas service.

10 Flow Coefficient (C_v)

- 2 = 0.06
- 6 = 0.25

11 Sensing Mechanism, Vent

- U = 316 SS piston, self and captured vent

12 Handle, Mounting

- 2 = Knob
 - 6 = Knob, panel mount
- For knob handle color options, see page 56.

13 Isolation Valves

- 0 = No valves
- For isolation valve options, see page 54.

14 Cylinder Connections

- 0 = No connections

15 Gauges

- 0 = No gauges
- For inlet and outlet gauge options, see page 54.

16 Options

- 0 = No options

General-Purpose Diaphragm-Sensing Back-Pressure Regulators (KBP Series)

The KBP series is a high-sensitivity, general-purpose regulator designed to control back-pressure levels in analytical or process systems upstream of the regulator. The convoluted diaphragm provides excellent sensitivity and set-point repeatability. The metal-to-metal diaphragm seal minimizes the potential for leakage.

Features

- Convoluted, nonperforated diaphragm
- Metal-to-metal diaphragm seal
- Low internal volume
- Two-piece cap design provides linear load on the seal

Technical Data

Maximum Inlet Pressure

- Equal to pressure control range

Pressure Control Ranges

- 0 to 10 psig (0.68 bar) through 0 to 500 psig (34.4 bar)

Flow Coefficient (C_v)

- 0.20

See page 49 for flow graphs.

Maximum Operating Temperature

- 176°F (80°C) with PCTFE retainer seal
- 392°F (200°C) with PEEK retainer seal

Weight

- 2.4 lb (1.1 kg)

Ports

- 1/4 in. female NPT inlet, outlet, and gauge ports (all body materials)
- 1/4 in. tube stub inlet, outlet, and gauge ports (316 SS body material only)
- 1/4 in. VCR inlet, outlet, and gauge ports (316 SS body material only)



Materials of Construction

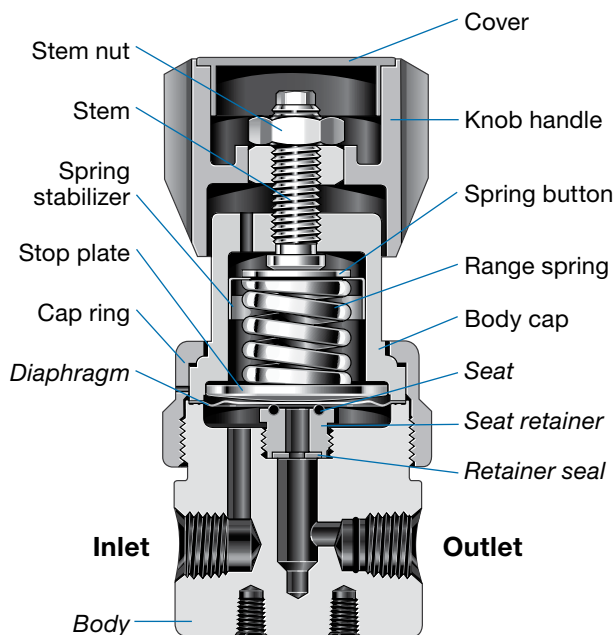

Component	316 SS	Brass CW721R
	Material	
Knob handle, cover	Nylon with 316 SS insert	
Spring button	316 SS (0 to 500 psig range) Zinc-plated steel (all other ranges)	
Spring stabilizer ^①	301 SS	
Range spring	316 SS (0 to 10 through 0 to 50 psig control ranges) Zinc-plated steel (0 to 100 through 0 to 500 psig control ranges)	
Stem, stem nut, cap ring, stop plate, body cap, panel nuts ^②	316 SS	
VCR nuts ^②	316 SS	—
Nonwetted lubricant	Hydrocarbon-based	
Seat retainer	316 SS	
Retainer seal	PCTFE or PEEK	
Seat	Fluorocarbon FKM or Kalrez	
Diaphragm ^③	Alloy X-750	
Body	316 SS	Brass CW721R
Tube stub ports, ^② VCR gland ports ^②	316L SS	—
Wetted lubricant	PTFE-based	

Wetted components listed in *italics*.

① Not included in regulators with 0 to 500 psig (0 to 34.4 bar) control range.

② Not shown.

③ Regulators with control ranges higher than 0 to 100 psig (0 to 6.8 bar) are assembled with two diaphragms.

Dimensions

Dimensions, in inches (millimeters), are for reference only and are subject to change.

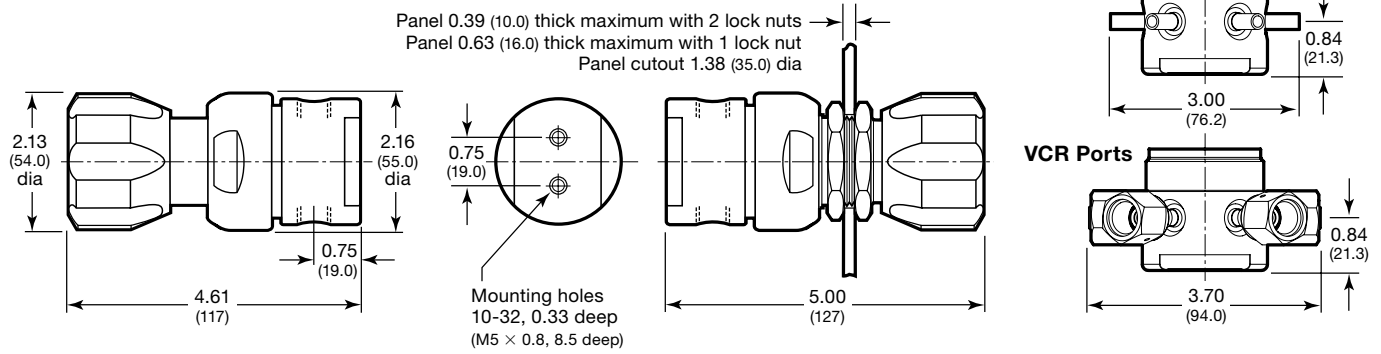

Ordering Information

Build a KBP series regulator ordering number by combining the designators in the sequence shown below.

4
5
6
7
8
9
10
11
12
13
14
15
16
KBP 1 F 0 D 4 A 5 A 2 0 0 0 0

4 Body Material

- 1 = 316 SS
- 2 = Brass CW721R
- A = 316 SS, ASTM G93 Level E-cleaned
- B = Brass, ASTM G93 Level E-cleaned
- C = 316 SS, SC-11-cleaned
- D = Brass, SC-11-cleaned

5 Pressure Control Range

- C = 0 to 10 psig (0 to 0.68 bar)
- D = 0 to 25 psig (0 to 1.7 bar)
- E = 0 to 50 psig (0 to 3.4 bar)
- F = 0 to 100 psig (0 to 6.8 bar)
- G = 0 to 250 psig (0 to 17.2 bar)
- J = 0 to 500 psig (0 to 34.4 bar)

6 Maximum Inlet Pressure

- 0 = Not applicable (equal to pressure control range)

7 Port Configuration

- A, D, G, V
- See *Port Configurations*, page 52.

8 Ports

- 4 = 1/4 in. female NPT
- T = 1/4 in. × 0.035 in. tube stub^①
- V = 1/4 in. VCR gland, no nuts^{①②}
- X = 1/4 in. rotatable female VCR fitting^①
- Y = 1/4 in. rotatable male VCR fitting^①

① Available only with 316 SS body material in A port configuration. Not available ASTM G93 Level E-cleaned.
 ② For use with VCR split-nuts, which can be ordered separately. See the Swagelok *VCR Metal Gasket Face Seal Fittings* catalog, MS-01-24.

9 Seat, Seal Material

- A = Fluorocarbon FKM, PCTFE
- B = Kalrez, PCTFE
- C = Fluorocarbon FKM, PEEK
- D = Kalrez, PEEK

10 Flow Coefficient (C_v)

- 5 = 0.20

11 Sensing Mechanism, Vent

- A = Alloy X-750 diaphragm, no vent
- E = Alloy X-750 diaphragm, captured vent, no self vent

12 Handle, Mounting

- 2 = Knob
- 3 = 316 SS antitamper nut
- 6 = Knob, panel mount
- 7 = 316 SS antitamper nut, panel mount

For knob handle color options, see page 56.

13 Valves

- 0 = No valves

14 Cylinder Connections

- 0 = No connections

15 Gauges

- 0 = No gauges
- For inlet gauge options, see page 54.

16 Options

- 0 = No options

High-Flow, High-Sensitivity Diaphragm-Sensing Back-Pressure Regulators (KFB Series)

The KFB series regulator is designed to maintain back-pressure control in high-flow applications with a C_v of 1.0.

Features

- Large-diameter convoluted, nonperforated diaphragm for increased pressure sensitivity
- Metal-to-metal diaphragm seal

Technical Data

Maximum Inlet Pressure

- Equal to pressure control range

Pressure Control Ranges

- 0 to 10 psig (0.68 bar) through 0 to 250 psig (17.2 bar)

Flow Coefficient (C_v)

- 1.0

See page 49 for flow graphs.

Maximum Operating Temperature

- 176°F (80°C) with PCTFE retainer seal
- 392°F (200°C) with PEEK retainer seal

Weight

- 4.4 lb (2.0 kg)

Ports

- 1/2 in. female NPT inlet and outlet;
1/4 in. female NPT gauge port



Materials of Construction

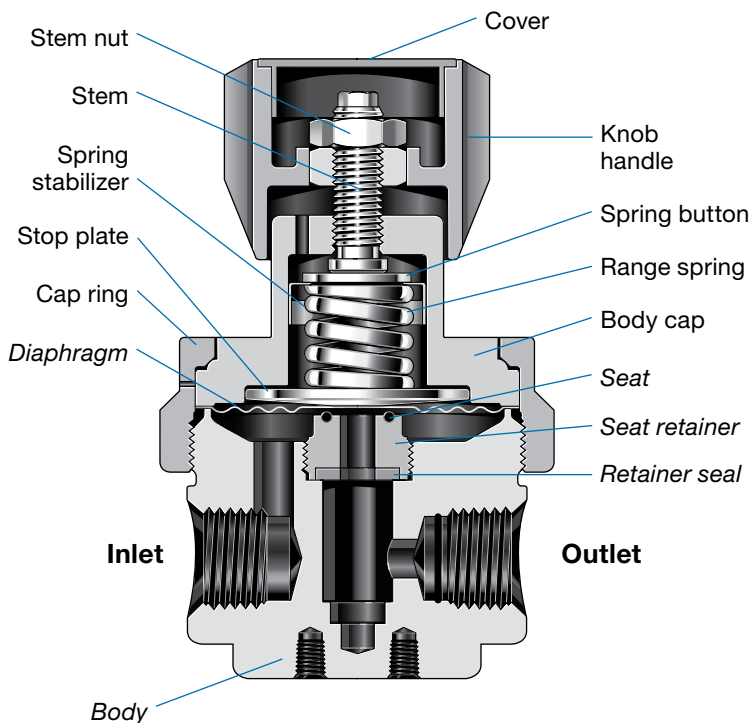

Component	Material
Knob handle, cover	Nylon with 316 SS insert
Spring button	316 SS (0 to 250 psig range) Zinc-plated steel (all other ranges)
Spring stabilizer ^①	301 SS
Range spring	316 SS (0 to 10 and 0 to 25 psig control ranges) Zinc-plated steel (0 to 50 through 0 to 250 psig control ranges)
Stem, stem nut, cap ring, stop plate, body cap, panel nuts ^②	316 SS
Nonwetted lubricant	Hydrocarbon-based
<i>Body, seat retainer</i>	316 SS
<i>Retainer seal</i>	PCTFE or PEEK
<i>Seat</i>	Fluorocarbon FKM
<i>Diaphragm^③</i>	Alloy X-750
<i>Wetted lubricant</i>	PTFE-based

Wetted components listed in *italics*.

① Not included in regulators with 0 to 250 psig (0 to 17.2 bar) control range.

② Not shown.

③ Regulators with control range 0 to 250 psig (0 to 17.2 bar) are assembled with two diaphragms.

Dimensions

Dimensions, in inches (millimeters), are for reference only and are subject to change.

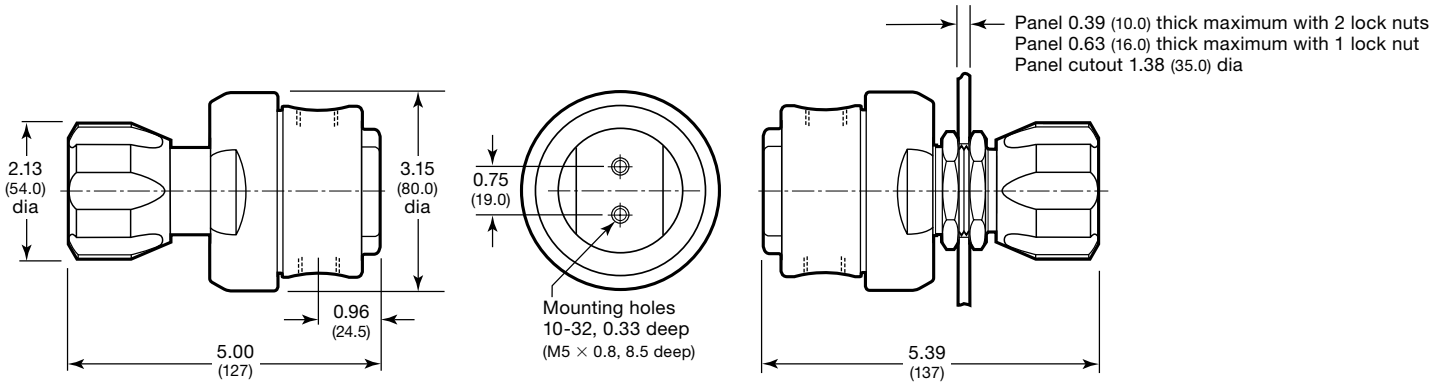

Ordering Information

Build a KFB series regulator ordering number by combining the designators in the sequence shown below.

4 5 6 7 8 9 10 11 12 13 14 15 16
KFB 1 F 0 D 8 A 8 A 1 0 0 0 0

4 Body Material

- 1 = 316 SS
- A = 316 SS, ASTM G93 Level E-cleaned

5 Pressure Control Range

- C = 0 to 10 psig (0 to 0.68 bar)
- D = 0 to 25 psig (0 to 1.7 bar)
- E = 0 to 50 psig (0 to 3.4 bar)
- F = 0 to 100 psig (0 to 6.8 bar)
- G = 0 to 250 psig (0 to 17.2 bar)

6 Maximum Inlet Pressure

- 0 = Not applicable (equal to pressure control range)

7 Port Configuration

- A, D, G, V
- See **Port Configurations**, page 52.

8 Ports

- 8 = 1/2 in. female NPT inlet and outlet;
1/4 in. female NPT gauge port

9 Seat, Seal Material

- A = Fluorocarbon FKM, PCTFE
- C = Fluorocarbon FKM, PEEK

10 Flow Coefficient (C_v)

- 8 = 1.0

11 Sensing Mechanism, Vent

- A = Alloy X-750 diaphragm, no vent
- E = Alloy X-750 diaphragm, captured vent, no self vent

12 Handle, Mounting

- 2 = Knob
- 3 = 316 SS antitamper nut
- 6 = Knob, panel mount
- 7 = 316 SS antitamper nut, panel mount
- For knob handle color options, see page 56.

13 Valves

- 0 = No valves

14 Cylinder Connections

- 0 = No connections

15 Gauges

- 0 = No gauges
- For inlet gauge options, see page 54.

16 Options

- 0 = No options

Compact Piston-Sensing Back-Pressure Regulators (KCB Series)

The KCB series provides high sensitivity back-pressure control of sampling conditioning systems. It is ideally suited for use in portable or laboratory analytical systems as well as being embedded in the instrument bays of OEM equipment or sampling cabinets.

Features

- Low internal volume
- Fully contained piston
- Excellent flow characteristics with a C_v of 0.20
- ANSI/ISA 76.00.02-compliant modular platform component (MPC) configuration available

Technical Data

Maximum Inlet Pressure

- Equal to pressure control range

Pressure Control Ranges

- 0 to 10 psig (0.68 bar) through 0 to 375 psig (25.8 bar)

Flow Coefficient (C_v)

- 0.20

See page 49 for flow graphs.

- 0.10 also available with MPC platform

Maximum Operating Temperature

- 176°F (80°C) with PCTFE retainer seal
- 392°F (200°C) with PEEK retainer seal

Weight

- 1.0 lb (0.5 kg)

Ports

- 1/8 in. female NPT inlet and outlet(s)
- MPC platform



Materials of Construction

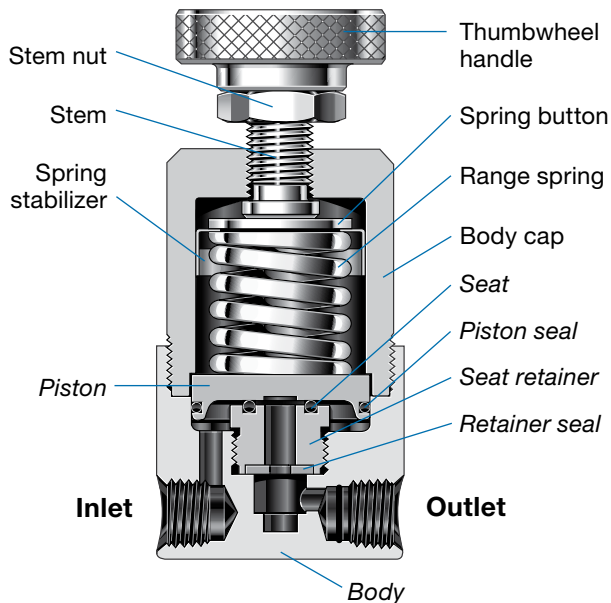

Component	Material
Thumbwheel handle	Anodized aluminum
Knob handle, ^① cover ^①	Nylon with 316 SS insert
Spring button	Zinc-plated steel
Spring stabilizer	301 SS
Range spring	316 SS (0 to 10 through 0 to 50 and 0 to 375 psig control ranges) Zinc-plated steel (all other control ranges)
Stem, stem nut, body cap, panel nuts ^①	316 SS
Nonwetted lubricant	Hydrocarbon-based
Body, seat retainer, piston	316 SS
Seat, piston seal	Fluorocarbon FKM or Kalrez
Retainer seal	PCTFE or PEEK
Wetted lubricant	PTFE-based

Wetted components listed in *italics*.

^① Not shown.

Dimensions

Dimensions, in inches (millimeters), are for reference only and are subject to change.

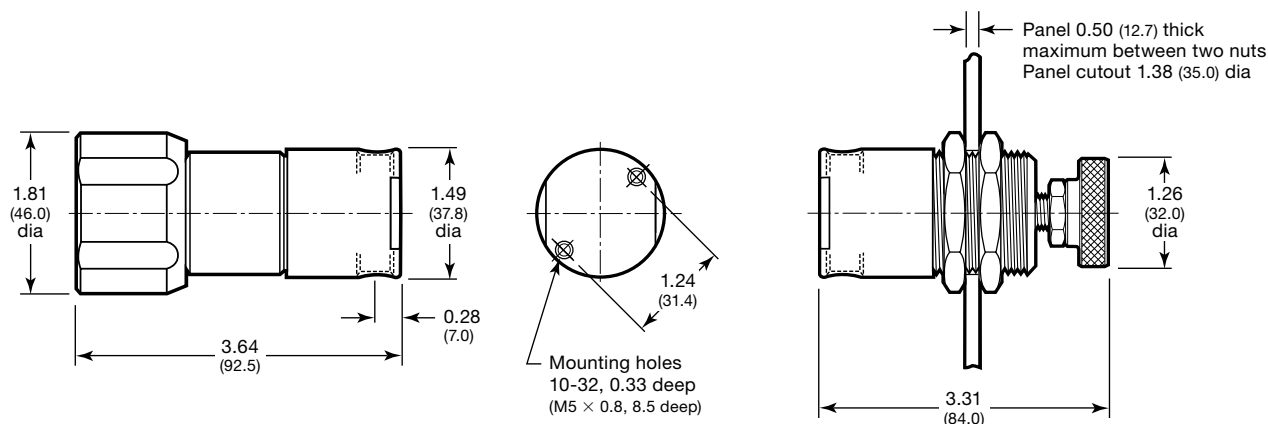

Ordering Information

Build a KCB series regulator ordering number by combining the designators in the sequence shown below.

4 5 6 7 8 9 10 11 12 13 14 15 16
KCB 1 F 0 D 2 A 5 P 1 0 0 0 0

4 Body Material

- 1 = 316 SS
- A = 316 SS, ASTM G93 Level E-cleaned
- C = 316 SS, SC-11-cleaned

5 Pressure Control Range

- C = 0 to 10 psig (0 to 0.68 bar)
- D = 0 to 25 psig (0 to 1.7 bar)
- E = 0 to 50 psig (0 to 3.4 bar)
- F = 0 to 100 psig (0 to 6.8 bar)
- G = 0 to 250 psig (0 to 17.2 bar)
- H = 0 to 375 psig (0 to 25.8 bar)

6 Maximum Inlet Pressure

- 0 = Not applicable (equal to pressure control range)

7 Port Configuration

- A, D, G, V, 7, 8
- See *Port Configurations*, page 52.

8 Ports

- 2 = 1/8 in. female NPT
- M = MPC platform

9 Seat, Retainer Seal Material

- A = Fluorocarbon FKM, PCTFE
- B = Kalrez, PCTFE
- C = Fluorocarbon FKM, PEEK
- D = Kalrez, PEEK

10 Flow Coefficient (C_v)

- 4 = 0.10 (MPC platform only)
- 5 = 0.20 (1/8 in. female NPT ports only)

11 Sensing Mechanism

- P = 316 SS piston

12 Handle, Mounting

- 1 = Thumbwheel^①
- 2 = Knob
- 3 = 316 SS antitamper nut
- 5 = Thumbwheel, panel mount^①
- 6 = Knob, panel mount
- 7 = 316 SS antitamper nut, panel mount

For knob handle color options, see page 56.

^① Not available with 0 to 375 psig (0 to 25.8 bar) pressure control range.

13 Valves

- 0 = No valves

14 Cylinder Connections

- 0 = No connections

15 Gauges

- 0 = No gauges
- For inlet gauge options, see page 54.

16 Options

- 0 = No options

Medium- to High-Pressure Piston-Sensing Back-Pressure Regulators (KPB Series)

The KPB series provides back-pressure control in gas or liquid applications. This compact and lightweight regulator provides an ideal pressure-control solution within high-density compact OEM equipment, as well as other applications.

Features

- Integral high-pressure overrange protection
- Lightweight, compact design

Technical Data

Maximum Inlet Pressure

- Equal to pressure control range

Pressure Control Ranges

- 0 to 1000 psig (68.9 bar) through 0 to 4000 psig (275 bar)

Flow Coefficient (C_v)

- 0.06 and 0.2

See page 50 for flow graphs.

Maximum Operating Temperature

- 176°F (80°C) with PCTFE seat
- 392°F (200°C) with PEEK seat

Weight

- 2.5 lb (1.2 kg)

Ports

- 1/4 in. female NPT inlet, outlet, and gauge ports



Materials of Construction

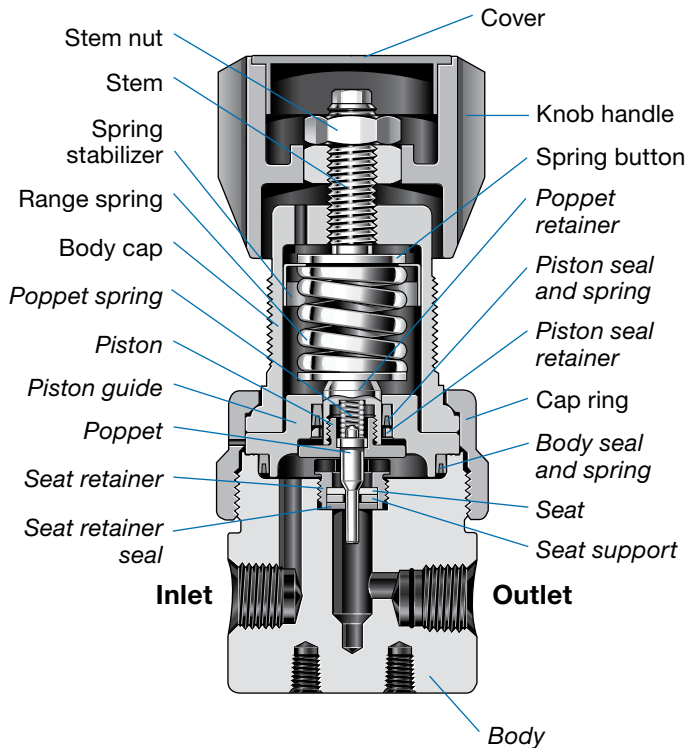

Component	Material
Knob handle, cover	Nylon with 316 SS insert
Spring button	316 SS (0 to 500 psig range) Zinc-plated steel (all other ranges)
Spring stabilizer ^①	301 SS
Range spring	316 SS (0 to 3000 and 0 to 4000 psig range) Zinc-plated steel (all other ranges)
Stem, stem nut, cap ring, body cap, panel nuts ^②	316 SS
Nonwetted lubricant	Hydrocarbon-based
<i>Body, seat retainer, seat support, poppet retainer, piston, piston guide</i>	316 SS
<i>Seat, seat retainer seal</i>	PCTFE or PEEK
<i>Piston seal retainer</i>	PEEK
<i>Poppet</i>	S17400 SS
<i>Poppet spring</i>	302 SS
<i>Piston seal, body seal</i>	PTFE
<i>Piston seal spring, body seal spring</i>	Elgiloy
<i>Wetted lubricant</i>	PTFE-based

Wetted components listed in *italics*.

① Not included in regulators with 0 to 3000 psig (0 to 206 bar) and 0 to 4000 psig (0 to 275 bar) control ranges.

② Not shown.

Dimensions

Dimensions, in inches (millimeters), are for reference only and are subject to change.

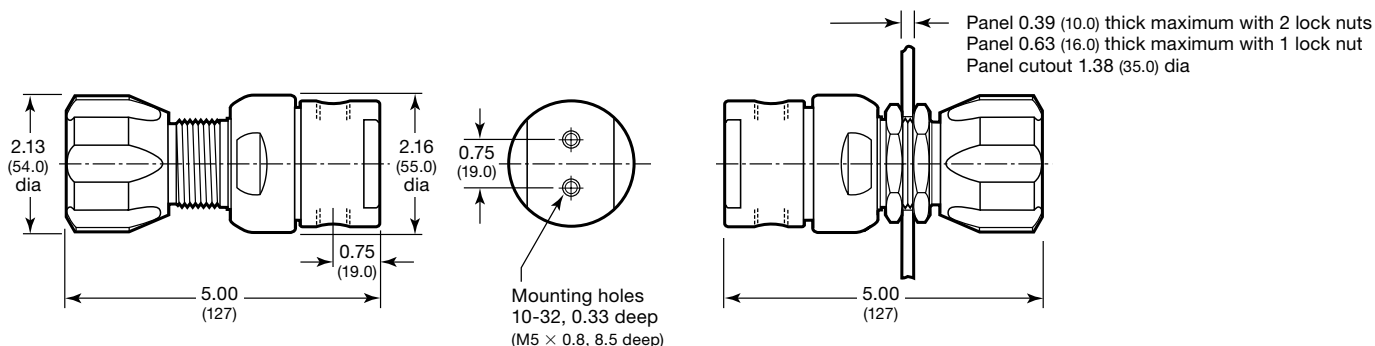

Ordering Information

Build a KPB series regulator ordering number by combining the designators in the sequence shown below.

4 5 6 7 8 9 10 11 12 13 14 15 16
KPB 1 L 0 A 4 2 2 P 2 0 0 0 0

4 Body Material

- 1 = 316 SS
- A = 316 SS, ASTM G93 Level E-cleaned

5 Pressure Control Range

- L = 0 to 1000 psig (0 to 68.9 bar)
- N = 0 to 2000 psig (0 to 137 bar)
- P = 0 to 3000 psig (0 to 206 bar)
- S = 0 to 4000 psig (0 to 275 bar)

6 Maximum Inlet Pressure

- 0 = Not applicable (equal to pressure control range)

7 Port Configuration

A, D, G, V
 See *Port Configurations*, page 52.

8 Ports

- 4 = 1/4 in. female NPT

9 Seat, Seal Material

- 1 = PCTFE
- 2 = PEEK

10 Flow Coefficient (C_v)

- 2 = 0.06
- 5 = 0.20

11 Sensing Mechanism

- P = 316 SS piston

12 Handle, Mounting

- 2 = Knob
- 3 = 316 SS antitamper nut
- 6 = Knob, panel mount
- 7 = 316 SS antitamper nut, panel mount

For knob handle color options, see page 56.

13 Valves

- 0 = No valves

14 Cylinder Connections

- 0 = No connections

15 Gauges

- 0 = No gauges
- For inlet gauge options, see page 54.

16 Options

- 0 = No options

High-Pressure Piston-Sensing Back-Pressure Regulators (KHB Series)

The KHB series provides control of back pressures up to 10 000 psig (689 bar) with high sensitivity across the control range.

Features

- Thrust roller bearing eases operation
- Panel-mounting configuration available

Technical Data

Maximum Inlet Pressure

- Equal to pressure control range

Pressure Control Ranges

- 0 to 500 psig (34.4 bar) through 100 to 10 000 psig (6.8 to 689 bar)

Flow Coefficient (C_v)

- 0.06 and 0.25

See page 51 for flow graphs.

Maximum Operating Temperature

- 212°F (100°C)

Weight

- 5.7 lb (2.6 kg)

Ports

- 1/4 in. female NPT inlet, outlet, and gauge ports



Materials of Construction

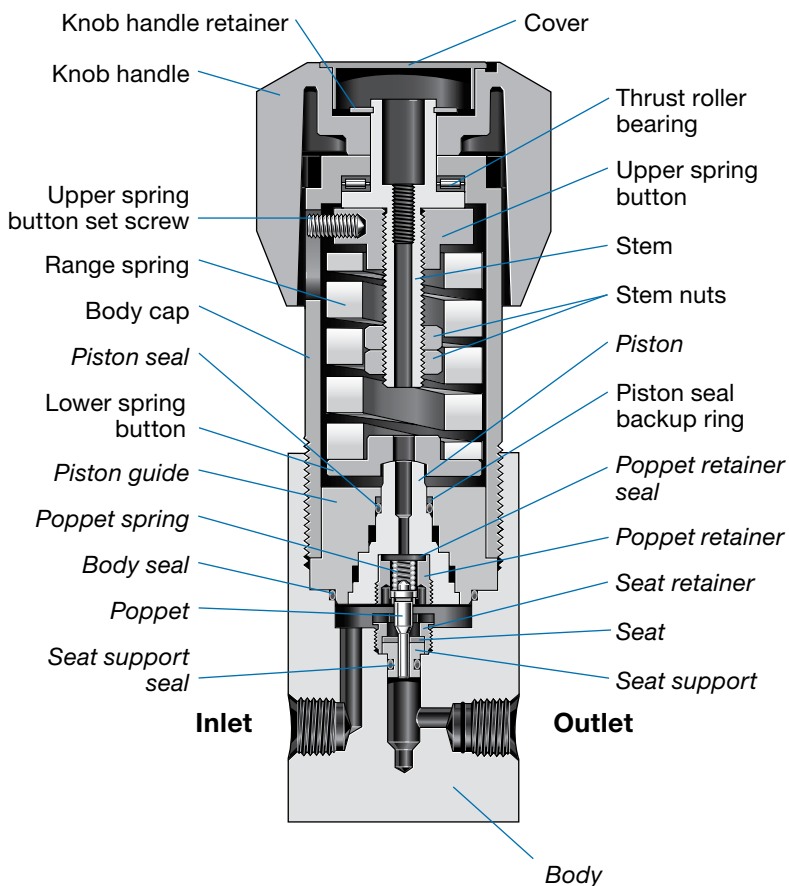

Component	Material
Knob handle, cover	Nylon with 316 SS insert
Spring buttons, upper spring button set screw, knob handle retainer, stem nuts, body cap	316 SS
Stem	CZ114 bronze
Thrust roller bearing	Hardened carbon steel
Range spring	Chrome vanadium steel
Piston seal backup ring	PEEK
Nonwetted lubricant	Hydrocarbon-based
<i>Body, poppet retainer, seat retainer, seat support, piston, piston guide</i>	316 SS
<i>Seat</i>	PEEK or 316 SS
<i>Poppet retainer seal</i>	PEEK
<i>Poppet</i>	S17400 SS
<i>Poppet spring</i>	302 SS
<i>Piston seal, body seal, seat support seal</i>	Fluorocarbon FKM
<i>Wetted lubricant</i>	PTFE-based

Wetted components listed in italics.

Dimensions

Dimensions, in inches (millimeters), are for reference only and are subject to change.

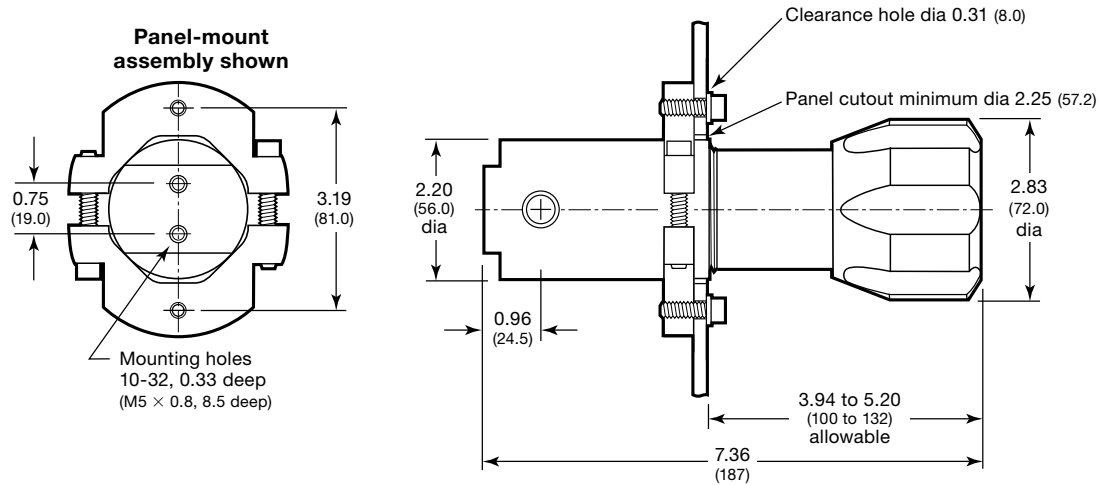

Ordering Information

Build a KHB series regulator ordering number by combining the designators in the sequence shown below.

4 5 6 7 8 9 10 11 12 13 14 15 16
KHB 1 T 0 D 4 C 2 P 2 0 0 0 0

4 Body Material

1 = 316 SS
 A = 316 SS, ASTM G93 Level E-cleaned

5 Pressure Control Range

J = 0 to 500 psig (0 to 34.4 bar)
 K = 0 to 750 psig (0 to 51.6 bar)
 T = 10 to 1500 psig (0.68 to 103 bar)
 U = 15 to 2500 psig (1.0 to 172 bar)
 V = 25 to 3600 psig (1.7 to 248 bar)
 W = 50 to 6000 psig (3.4 to 413 bar)
 X = 100 to 10 000 psig (6.8 to 689 bar)

6 Maximum Inlet Pressure

0 = Not applicable (equal to pressure control range)

7 Port Configuration

A, D, G, V

See **Port Configurations**, page 52.

8 Ports

4 = 1/4 in. female NPT

9 Seat, Piston/Body/Seat Support Seal Material

C = PEEK, fluorocarbon FKM
 J = 316 SS, fluorocarbon FKM^①

^① Not suitable for gas service.

10 Flow Coefficient (C_v)

2 = 0.06
 6 = 0.25

11 Sensing Mechanism

P = 316 SS piston

12 Handle, Mounting

2 = Knob
 6 = Knob, panel mount

For knob handle color options, see page 56.

13 Valves

0 = No valves

14 Cylinder Connections

0 = No connections

15 Gauges

0 = No gauges

For inlet gauge options, see page 54.

16 Options

0 = No options

Gas Cylinder Changeover Regulator (KCM Series)

The KCM series is a two-stage gas delivery system that ensures continuous flow of gases in critical applications. When one supply drops below the changeover pressure, the selector regulator automatically switches the gas feed from the depleted supply to an alternate supply. The automatic operation of the KCM series eliminates costly system downtime and maintenance expense of continuously monitoring the gas supply.

Features

- Convoluted, nonperforated diaphragm for strength and improved pressure response
- Metal-to-metal diaphragm seals on all stages
- Supply-pressure effect of approximately 0.01 %
- Bracket mount

Technical Data

Maximum Inlet Pressure

- 3600 psig (248 bar)
- 3000 psig (206 bar) with hose and cylinder connection option

Pressure Control Ranges

- 0 to 10 psig (0.68 bar) through 0 to 500 psig (34.4 bar)

Nominal Changeover Pressures

- 100, 250, and 500 psig (6.8, 17.2, and 34.4 bar)

Flow Coefficient (C_v)

- 0.06

Maximum Operating Temperature

- 176°F (80°C) with PCTFE seat
- 392°F (200°C) with PEEK seat

Weight

- 7.25 lb (3.3 kg)

Ports

- 1/4 in. female NPT inlet, outlet, and gauge ports



Shown with Swagelok tube fittings, not included.

Operation

The KCM series can be ordered to switch from one supply to another at one of three different inlet pressures—100, 250, and 500 psig (6.8, 17.2, and 34.4 bar)—called changeover pressures.

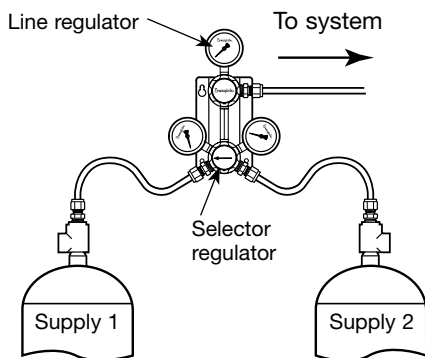

The selector regulator (first stage) is factory-set to reduce the supply pressure to the nominal changeover pressure ordered. The line regulator (second stage) can be adjusted with the handle to achieve the required system pressure. This two-stage arrangement minimizes the supply-pressure effect caused by depleting gas supplies (cylinders, tank farm, etc.).

When one supply drops below the changeover pressure, the selector regulator automatically switches the gas feed from the depleted supply to an alternate supply. If both supplies drop below the changeover pressure, the assembly functions as a single-stage regulator, depleting both supplies at the same time. See the **Approximate Supply Depletion Pressures** table at right for pressures at which this occurs.

The Swagelok KCA series continuous gas delivery system is a panel-mounted gas changeover assembly that can be configured for many applications. For more information, see the *Swagelok KCA Series Continuous Gas Delivery System* catalog, MS-18-01.

Materials of Construction

The KCM series gas changeover uses Swagelok KPR series pressure-reducing regulators. For more information, see **General-Purpose Diaphragm Sensing, Pressure-Reducing Regulators (KPR Series)**, page 6.

The table below lists additional components not shown in the KPR series section.

Component	Material
<i>Interstage fitting</i>	316 SS with PTFE tape
Line-regulator mounting block	Aluminum
Line-regulators mounting screws, mounting bracket	316 SS

Wetted components listed in *italics*.

Approximate Supply Depletion Pressures

Nominal Changeover Pressure psig (bar)	Supply 1 Depletion Pressure psig (bar)	Supply 2 Depletion Pressure psig (bar)
100 (6.8)	150 (10.3)	90 (6.2)
250 (17.2)	300 (20.6)	230 (15.8)
500 (34.4)	500 (34.4)	450 (31.0)

Supply 2 can deplete below some of the available pressure control range limits. Setting the line regulator near the nominal changeover pressure will cause flow to the system to decrease or stop as the supply nears depletion.

Dimensions

Dimensions, in inches (millimeters), are for reference only and are subject to change.

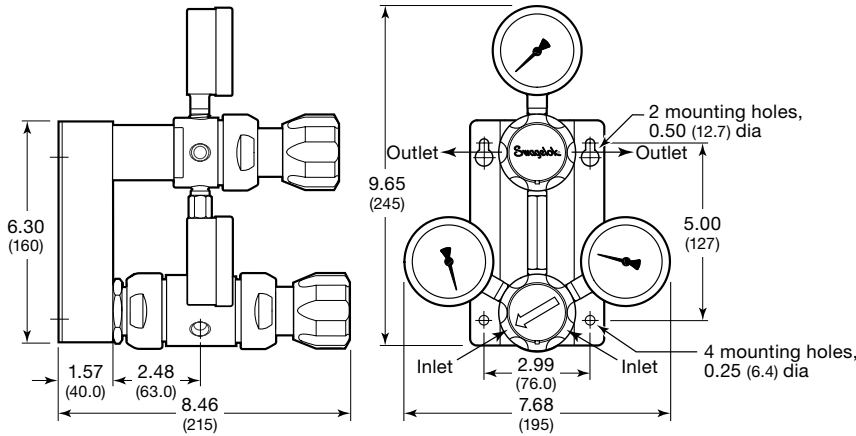

Ordering Information

Build a KCM series regulator ordering number by combining the designators in the sequence shown below.



4 Body Material

- 1 = 316 SS
- A = 316 SS, ASTM G93 Level E-cleaned

5 Pressure Control Range

- C = 0 to 10 psig (0 to 0.68 bar)
- D = 0 to 25 psig (0 to 1.7 bar)
- E = 0 to 50 psig (0 to 3.4 bar)
- F = 0 to 100 psig (0 to 6.8 bar)
- G = 0 to 250 psig (0 to 17.2 bar)^①
- J = 0 to 500 psig (0 to 34.4 bar)^②

^① Not available with 100 psig (6.8 bar) changeover pressure.
^② Only available with 500 psig (34.4 bar) changeover pressure.

6 Nominal Changeover Pressure^①

- F = 100 psig (6.8 bar)
- G = 250 psig (17.2 bar)
- J = 500 psig (34.4 bar)

^① Inlet pressure must exceed changeover pressure for automatic switching to occur.

7 Port Configuration

- B, C, L
- See **Port Configurations**, below.

8 Ports

- 4 = 1/4 in. female NPT

9 Seat Material

- 1 = PCTFE
- 2 = PEEK

10 Flow Coefficient (C_v)

- 2 = 0.06

11 Sensing Mechanism, Vent

- A = Alloy X-750 diaphragm, no vent
- C = Alloy X-750 diaphragm, self vent^①
- E = Alloy X-750 diaphragm, captured vent, no self vent^①
- F = Alloy X-750 diaphragm, self and captured vent^①

^① Self and captured vent options on line regulator only.

12 Line Regulator Handle

- D = Knob
 - E = 316 SS antitamper nut
- Selector regulator has knob handle. For knob handle color options, see page 56.

13 Isolation and Relief Valves

- 0 = No valves
- For isolation and relief valve options, see page 54.

14 Cylinder Connections

- 0 = No connections
- Cylinder connections available only with hose option. For CGA cylinder connection options, see page 53.

15 Gauge Scale

- 1 = psig (bar) (North America only)
- 2 = bar (psig)
- 3 = psig (bar)
- 4 = MPa
- 5 = psig (kPa)

For more information, see page 54.

16 Options

- 0 = No options
- 3 = 3 ft, 1/4 in. FM series metal flexible hose, 1/4 in. female NPT inlet^①
- 4 = 3 ft, 1/4 in. TH series PTFE-lined, stainless steel braided hose, 1/4 in. female NPT inlet^①

For more information about hoses, see page 56.

^① Hoses are not available for ASTM G93 Level E-cleaned regulators.

Port Configurations

Configuration	Designator	Configuration	Designator	Configuration	Designator
	B		C		L

G_o = Outlet gauge.
 G_o/R = Outlet gauge or relief valve.
 R = Relief valve.
 I = Isolation valve.

Steam-Heated Vaporizing, Diaphragm-Sensing Pressure-Reducing Regulator (KSV Series)

The KSV series is a steam-heated vaporizing regulator with a low internal volume. It can be used to vaporize liquid samples or to preheat gas samples to prevent them from condensing.

Features

- Convolute, nonperforated diaphragm
- Metal-to-metal diaphragm seal
- Low internal volume

Technical Data

Maximum Inlet Pressure

- 3600 psig (248 bar)

Outlet Pressure Ranges

- 0 to 10 psig (0.68 bar) through 0 to 500 psig (34.4 bar)

Flow Coefficient (C_v)

- 0.06 or 0.20

Maximum Steam Pressure and Temperature

- 650 psig (44.7 bar) and 500°F (260°C)

Maximum Regulator Operating Temperature

- 392°F (200°C)

Weight

- 3.3 lb (1.5 kg)

Ports

- 1/8 in. female NPT inlet; 1/4 in. female NPT outlet(s)
- Steam tube 1/2 in. outside diameter, 0.049 in. wall



Materials of Construction

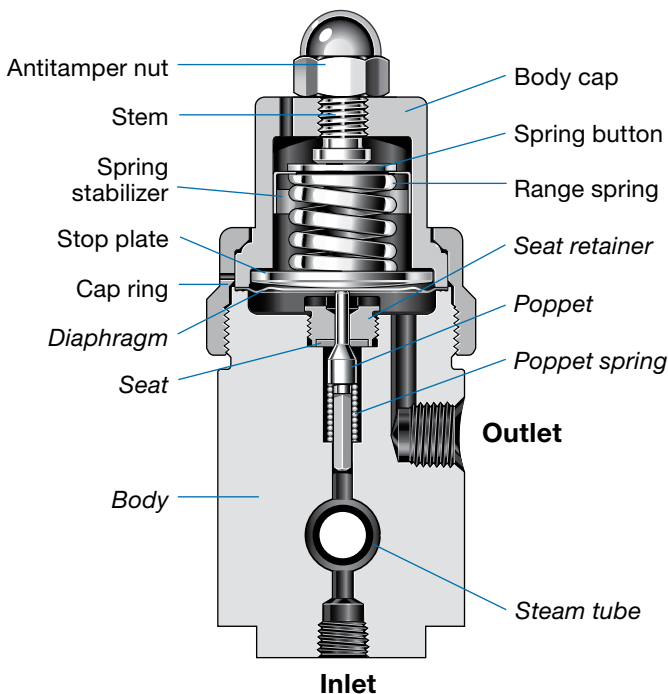

Component	Material
Antitamper nut, stem, cap ring, stop plate, body cap, panel nuts ^①	316 SS
Spring button	Zinc-plated steel
Spring stabilizer ^②	301 SS
Range spring	316 SS or zinc-plated steel, depending on configuration
Nonwetted lubricant	Hydrocarbon-based
<i>Body, seat retainer, steam tube</i>	316 SS
<i>Seat</i>	PEEK
<i>Diaphragm,^③ poppet spring</i>	Alloy X-750
<i>Poppet</i>	S17400 SS
<i>Wetted lubricant</i>	PTFE-based

Wetted components listed in *italics*.

^① Not shown.

^② Not required in all configurations.

^③ Regulators with control ranges higher than 0 to 100 psig (0 to 6.8 bar) are assembled with two diaphragms.

Dimensions

Dimensions, in inches (millimeters), are for reference only and are subject to change.

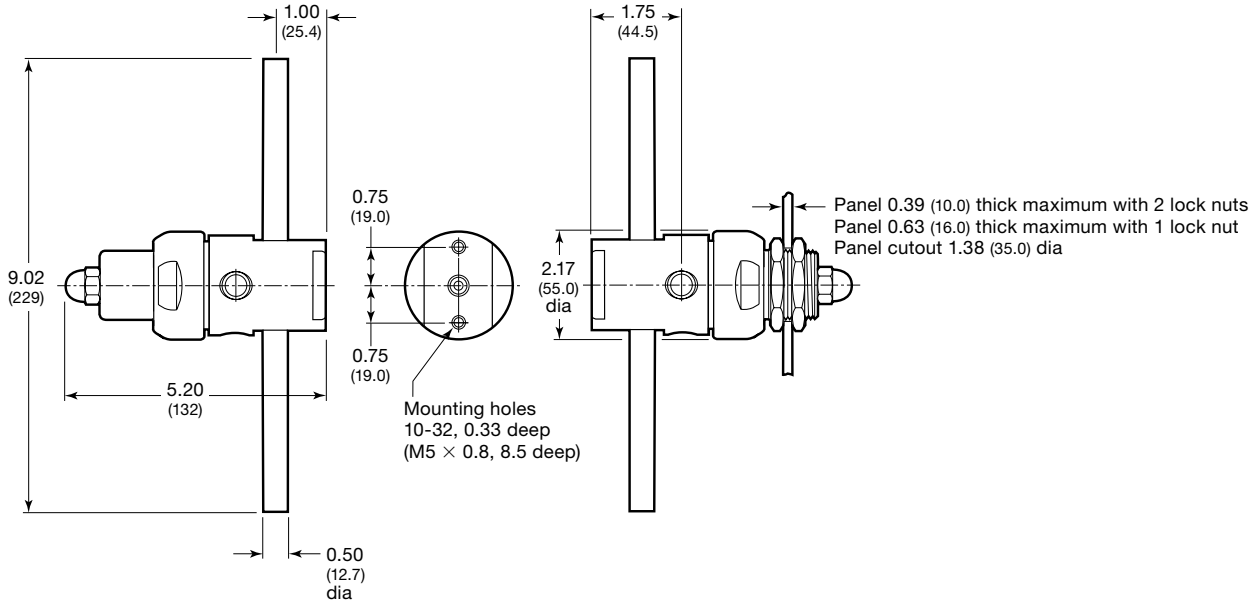

Ordering Information

Build a KSV series regulator ordering number by combining the designators in the sequence shown below.



4 Body Material

- 1 = 316 SS
- A = 316 SS, ASTM G93 Level E-cleaned

5 Pressure Control Range

- C = 0 to 10 psig (0 to 0.68 bar)
- D = 0 to 25 psig (0 to 1.7 bar)
- E = 0 to 50 psig (0 to 3.4 bar)
- F = 0 to 100 psig (0 to 6.8 bar)
- G = 0 to 250 psig (0 to 17.2 bar)
- J = 0 to 500 psig (0 to 34.4 bar)

6 Maximum Inlet Pressure^①

- F = 100 psig (6.8 bar)
- J = 500 psig (34.4 bar)
- L = 1000 psig (68.9 bar)
- R = 3600 psig (248 bar)

^① For better resolution and control, select a pressure that closely matches system pressure.

8 Ports

- 3 = 1/8 in. female NPT inlet;
- 1/4 in. female NPT outlet(s)

9 Seat Material

- 2 = PEEK

10 Flow Coefficient (C_v)

- 2 = 0.06
- 5 = 0.20

11 Sensing Mechanism, Vent

- A = Alloy X-750 diaphragm, no vent
- E = Alloy X-750 diaphragm, captured vent, no self vent

12 Handle, Mounting

- 3 = Antitamper nut
- 7 = Antitamper nut, panel mount

13 Valves

- 0 = No valves

14 Cylinder Connections

- 0 = No connections

15 Gauges

- 0 = No gauges

16 Options

- 0 = No options

7 Port Configuration

1, 4

See **Port Configurations, right.**

Port Configurations

Configuration	Designator	Configuration	Designator
	1		4

Electrically Heated Vaporizing Pressure-Reducing Regulator (KEV Series)



The KEV series is an electrically heated vaporizing regulator with a low internal volume. It can be used to vaporize liquid samples or to preheat gas samples to prevent them from condensing. It features a heating element that is in direct contact with the process fluid for maximum thermal efficiency and is removable for easy cleaning. The KEV regulator has an integral temperature controller and is rated for use in hazardous areas, as identified below.



Features

- Convolute, nonperforated diaphragm for control ranges up to 500 psig (34.4 bar)
- Stainless steel piston for control ranges from 1000 to 3600 psig (68.9 to 248 bar)
- ATEX, IECEx, and CSA certified for critical/hazardous environments
- T3 temperature classification for all heater ranges
- CE conformity: 89/336/EEC (EMC)
- Horizontally or vertically mounted
- One-piece body eliminates potential leak paths
- Low-volume vapor chamber for fast response
- Heater in direct contact with process media for maximum thermal efficiency
- Removable heater simplifies cleaning
- Side and base inlet options

Technical Data

Maximum Inlet Pressure

- 3600 psig (248 bar)

Pressure Control Ranges

- 0 to 10 psig (0.68 bar) through 0 to 3600 psig (248 bar)

Flow Coefficient (C_v)

- 0.02 or 0.06

Weight

- Side mounted—8.8 lb (4.0 kg)
- Base mounted—7.7 lb (3.5 kg)

Ports

- 1/8 in. female NPT inlet; 1/4 in. female NPT outlet

Electrical

- Supply—120 and 240 V (ac) ($\pm 10\%$), 50/60 Hz
- Heater ratings—50, 100, 150, and 200 W
- Control temperature range—75 to 380°F (23 to 193°C)
- Explosive atmosphere/hazardous location certification:
 - ATEX (Europe) and IECEx (international)—Group II, Category 2G, Exd IIB+H₂; T3
Ambient temperatures: -4 to 140°F (-20 to 60°C)
 - CSA (Canada and U.S.A.)—Class I, Div 1, Groups B, C, and D; T3; CSA Encl Type 4
Ambient temperatures: -58 to 122°F (-50 to 50°C)

⚠ Do not use with system fluids that are within their explosive range.

Materials of Construction

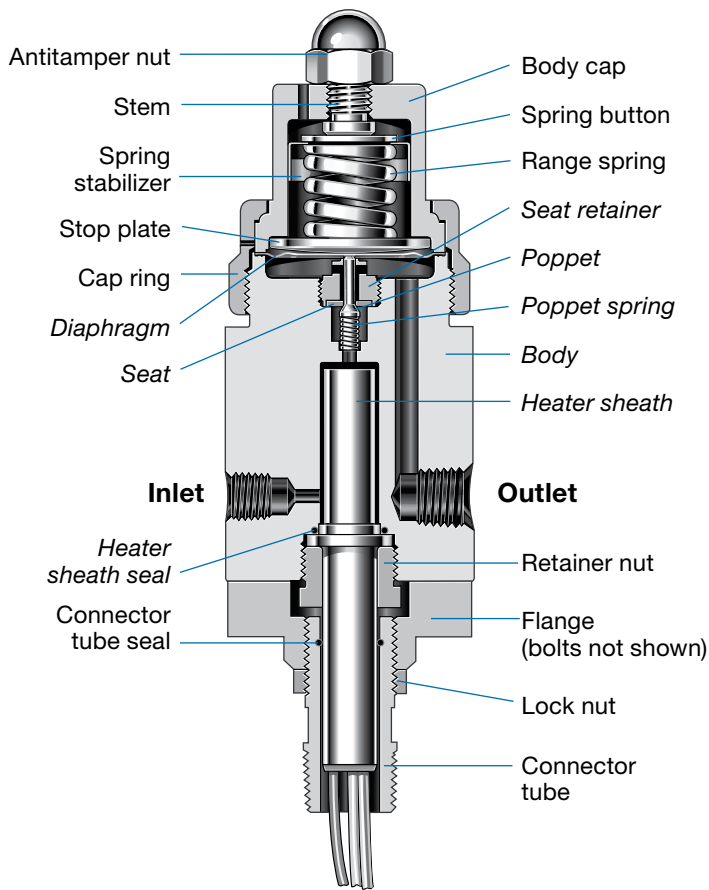

Component	Material
Antitamper nut, stem, cap ring, stop plate, ^① body cap, retainer nut, flange, flange bolts, lock nut, connector tube, panel nuts ^②	316 SS
Spring button	Zinc-plated steel
Spring stabilizer ^③	301 SS
Range spring	316 SS or zinc-plated steel, depending on configuration
Connector tube seal	Nitrile
Nonwetted lubricant	Hydrocarbon-based
<i>Body, seat retainer, heater sheath</i>	316 SS
<i>Heater sheath seal</i>	Alloy 718
<i>Seat</i>	PEEK
<i>Diaphragm^{①④}</i>	Alloy X-750
<i>Poppet</i>	S17400 SS
<i>Poppet spring</i>	302 SS
<i>Wetted lubricant</i>	PTFE-based
Piston Sensing Components	
<i>Piston seal, body seal</i>	PTFE
<i>Piston, piston guide</i>	316 SS
<i>Piston seal retainer</i>	PEEK
<i>Piston seal spring, body seal spring</i>	Elgiloy

Wetted components listed in *italics*.

① Not included in regulators with piston sensing mechanism.

② Not shown.

③ Not required in all configurations.

④ Regulators with control ranges 0 to 250 psig (0 to 17.2 bar) and 0 to 500 psig (0 to 34.4 bar) are assembled with two diaphragms.

Piston Sensing Mechanism

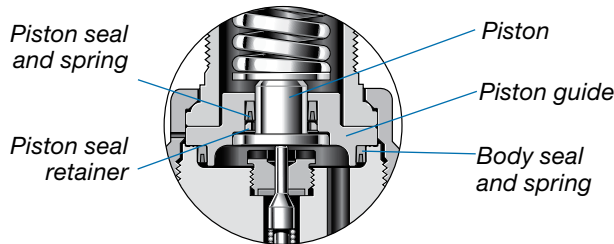

Dimensions

Dimensions, in inches (millimeters), are for reference only and are subject to change.

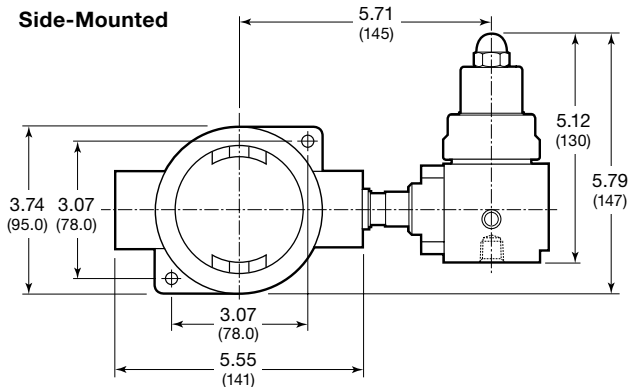

Base-Mounted

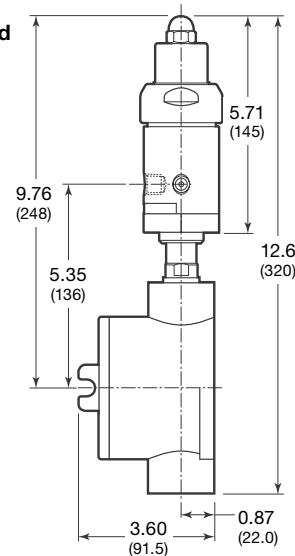

Ordering Information

Build a KEV series regulator ordering number by combining the designators in the sequence shown below.

4 5 6 7 8 9 10 11 12 13 14 15 16
KEV 1 F R A 3 2 2 A X 0 0 0 G

4 Body Material

- 1 = 316 SS
- A = 316 SS, ASTM G93 Level E-cleaned

5 Pressure Control Range

Diaphragm Sensing

- C = 0 to 10 psig (0 to 0.68 bar)
- D = 0 to 25 psig (0 to 1.7 bar)
- E = 0 to 50 psig (0 to 3.4 bar)
- F = 0 to 100 psig (0 to 6.8 bar)
- G = 0 to 250 psig (0 to 17.2 bar)
- J = 0 to 500 psig (0 to 34.4 bar)

Piston Sensing

- L = 0 to 1000 psig (0 to 68.9 bar)
- M = 0 to 1500 psig (0 to 103 bar)
- N = 0 to 2000 psig (0 to 137 bar)
- P = 0 to 3000 psig (0 to 206 bar)
- R = 0 to 3600 psig (0 to 248 bar)

6 Maximum Inlet Pressure^①

- F = 100 psig (6.8 bar)^②
- J = 500 psig (34.4 bar)^②
- L = 1000 psig (68.9 bar)^②
- R = 3600 psig (248 bar)

^① For better resolution and control, select a pressure that closely matches system pressure.
^② Available with diaphragm sensing mechanism only.

7 Port Configuration

- Side Mount—A, X, 1, 2
 - Base Mount—A, B, X, Y, Z
- See *Port Configurations*, below.

8 Ports

- 3 = 1/8 in. female NPT inlet;
- 1/4 in. female NPT outlet(s)

9 Seat Material

- 2 = PEEK

10 Flow Coefficient (C_v)

- 1 = 0.02
- 2 = 0.06

11 Sensing Mechanism

- A = Alloy X-750 diaphragm (outlet pressures up to 500 psig [34.4 bar])
- P = 316 SS piston (outlet pressures above 500 psig [34.4 bar])

12 Handle, Mounting

- W = Antitamper nut, side mount
- X = Antitamper nut, base mount

13 Valves

- 0 = No valves

14 Cylinder Connections

- 0 = No connections

15 Gauges

- 0 = No gauges

16 Heater, Controller

- | | |
|---|---|
| 75 to 380°F
(23 to 193°C), 120 V | 75 to 380°F
(23 to 193°C), 240 V |
| G = 50 W | 6 = 50 W |
| H = 100 W | 7 = 100 W |
| J = 150 W | 8 = 150 W |
| K = 200 W | 9 = 200 W |

Port Configurations^①

➔➔➔ Outlet and auxiliary ports on the same face.

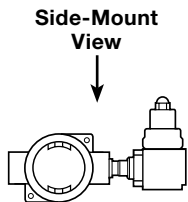

Designator	Configuration
1	Base inlet
2	Base inlet
A	
X	

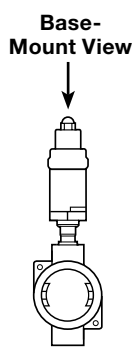

Designator	Configuration
Y	
Z	
A	
X	
B	

^① Regulator is rotatable 360° in relation to terminal box.

Pressure-Reducing Regulator Flow Data

The graphs illustrate the change or “droop” in outlet pressures as the flow rate increases.

KPR Series

Flow Coefficient 0.06;
Maximum Inlet Pressure 3600 psig (248 bar)

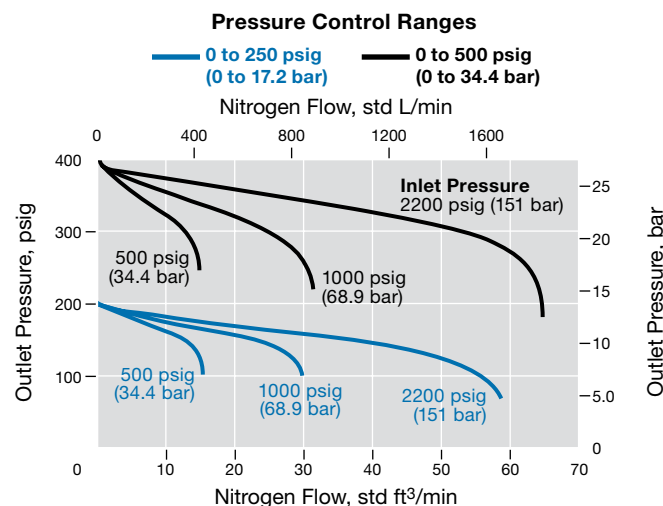
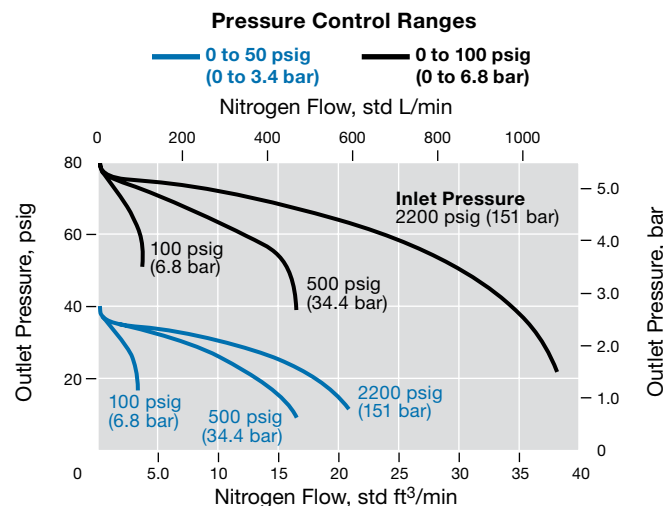
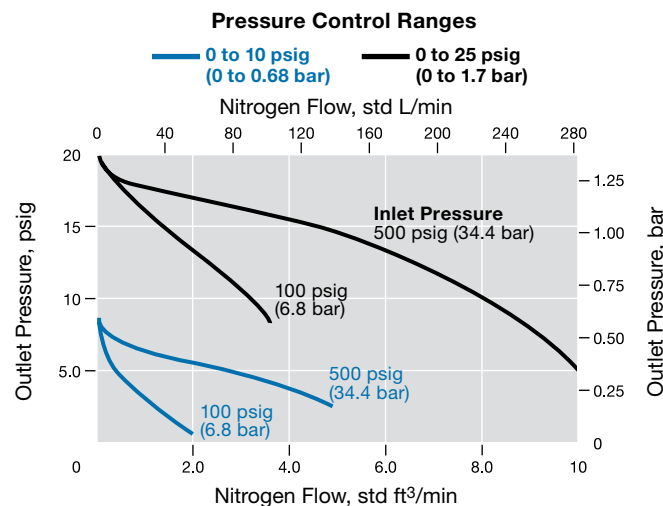

Flow Coefficient 0.20;
Maximum Inlet Pressure 3600 psig (248 bar)

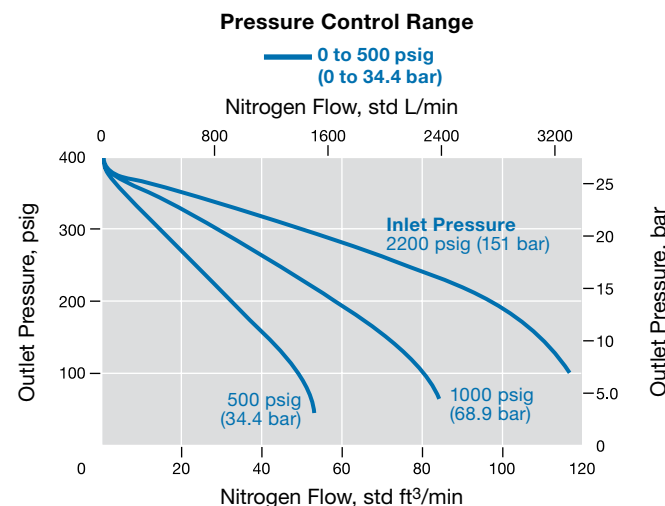
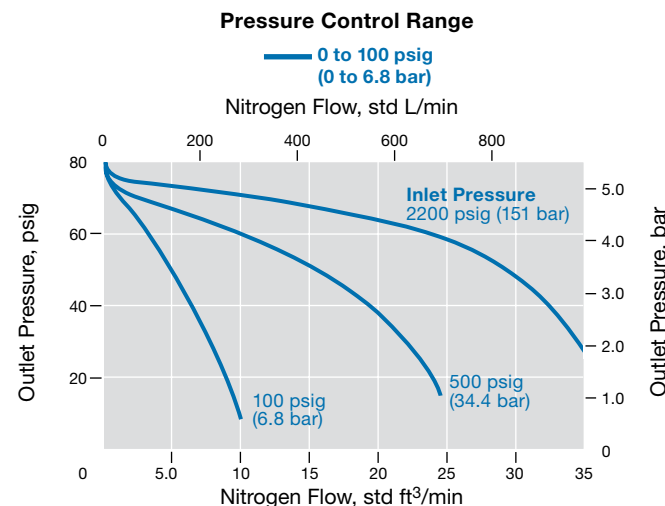
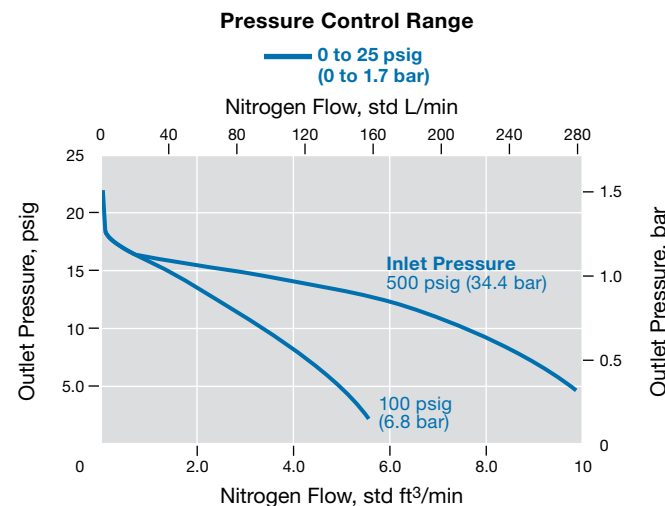

Pressure-Reducing Regulator Flow Data

The graphs illustrate the change or “droop” in outlet pressures as the flow rate increases.

KCY Series

**Flow Coefficient 0.06;
Maximum Inlet Pressure 3600 psig (248 bar)**

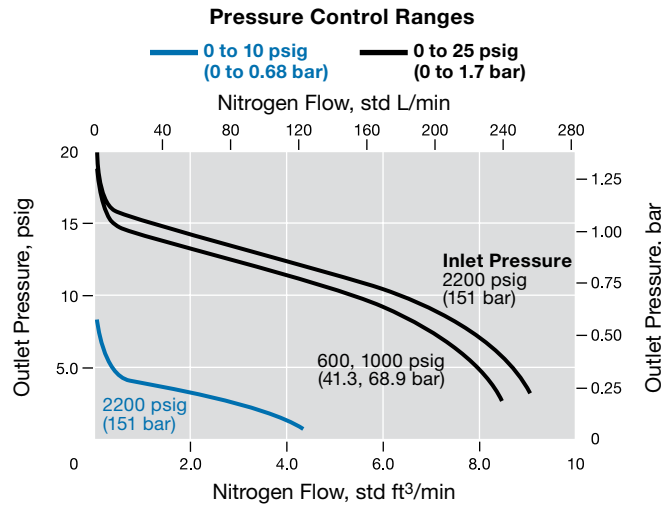

**Flow Coefficient 0.20;
Maximum Inlet Pressure 3600 psig (248 bar)**

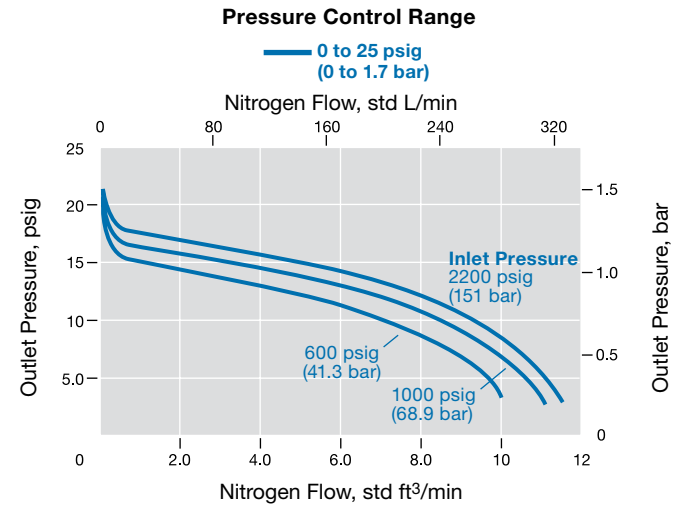

Pressure-Reducing Regulator Flow Data

The graphs illustrate the change or “droop” in outlet pressures as the flow rate increases.

KLF Series

Flow Coefficient 0.02;
Maximum Inlet Pressure 3600 psig (248 bar)

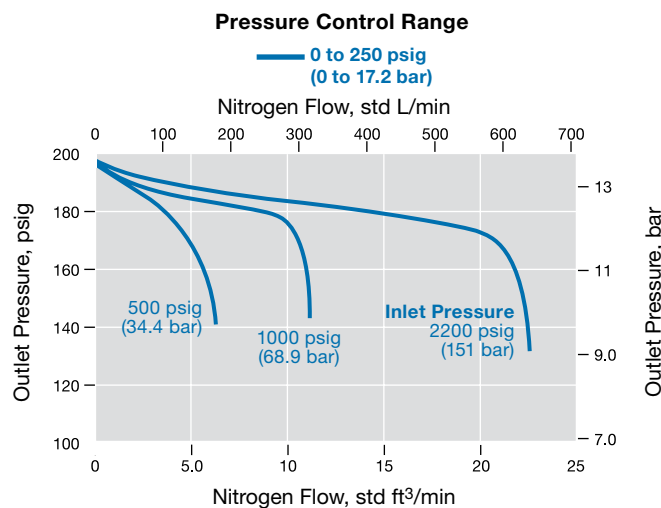
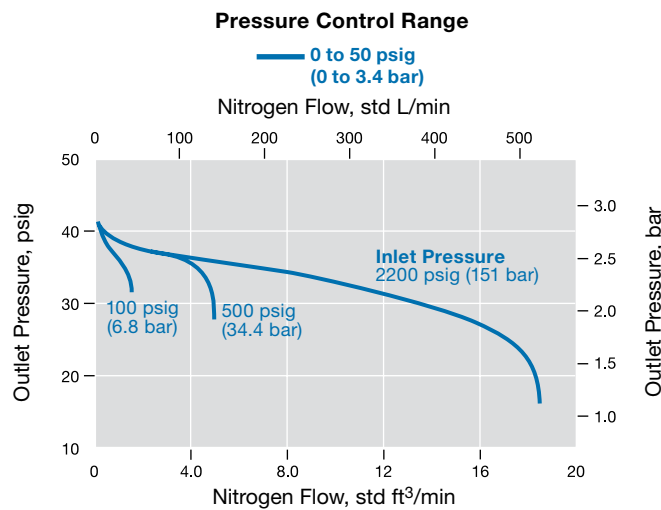
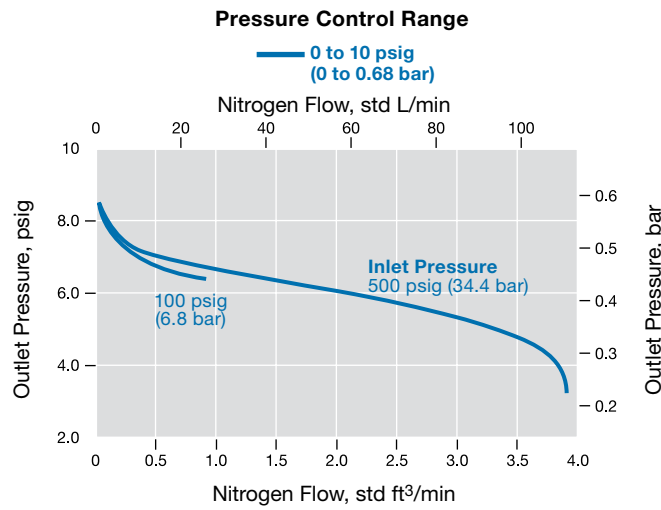

Flow Coefficient 0.06;
Maximum Inlet Pressure 3600 psig (248 bar)

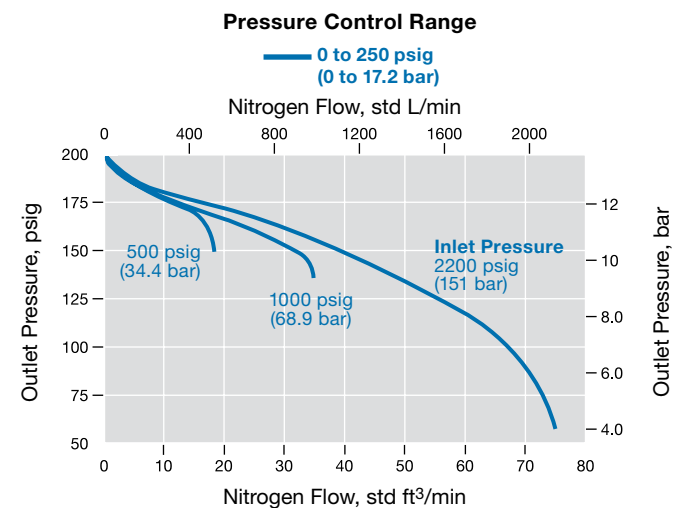
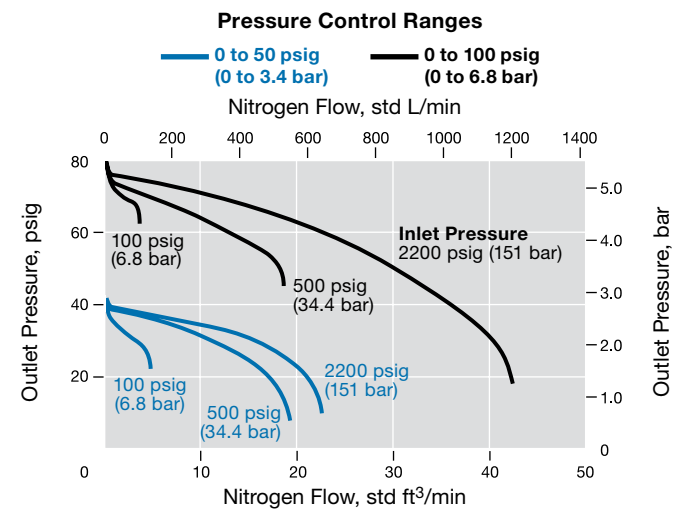
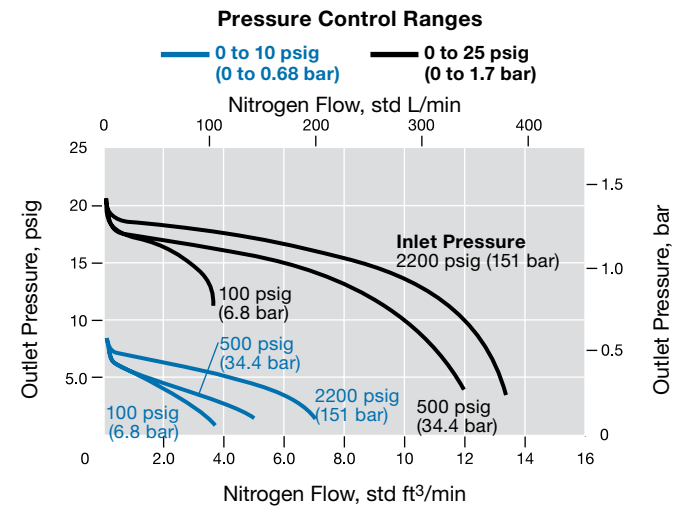

Pressure-Reducing Regulator Flow Data

The graphs illustrate the change or “droop” in outlet pressures as the flow rate increases.

KHF Series

**Flow Coefficient 1.0;
Maximum Inlet Pressure 3600 psig (248 bar)**

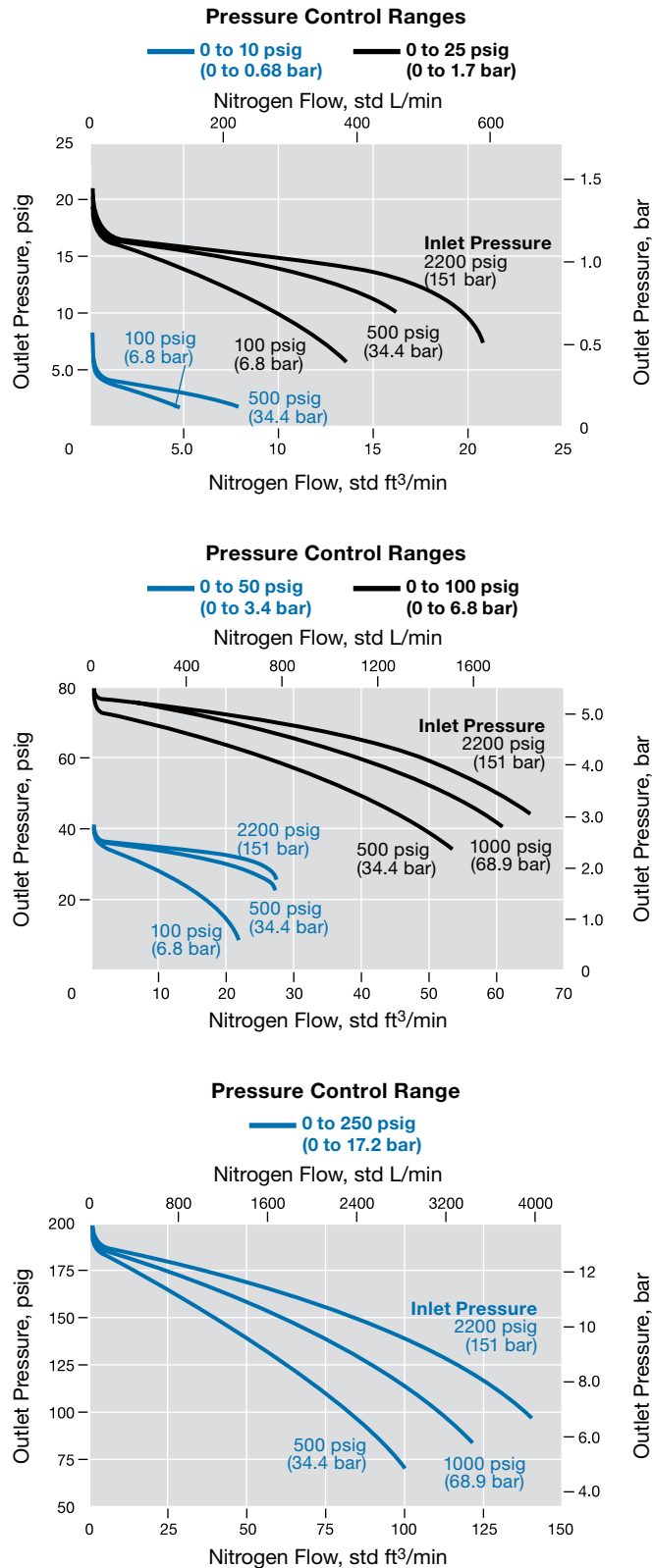

KPF Series

**Flow Coefficient 1.0;
Maximum Inlet Pressure 6000 psig (413 bar)**

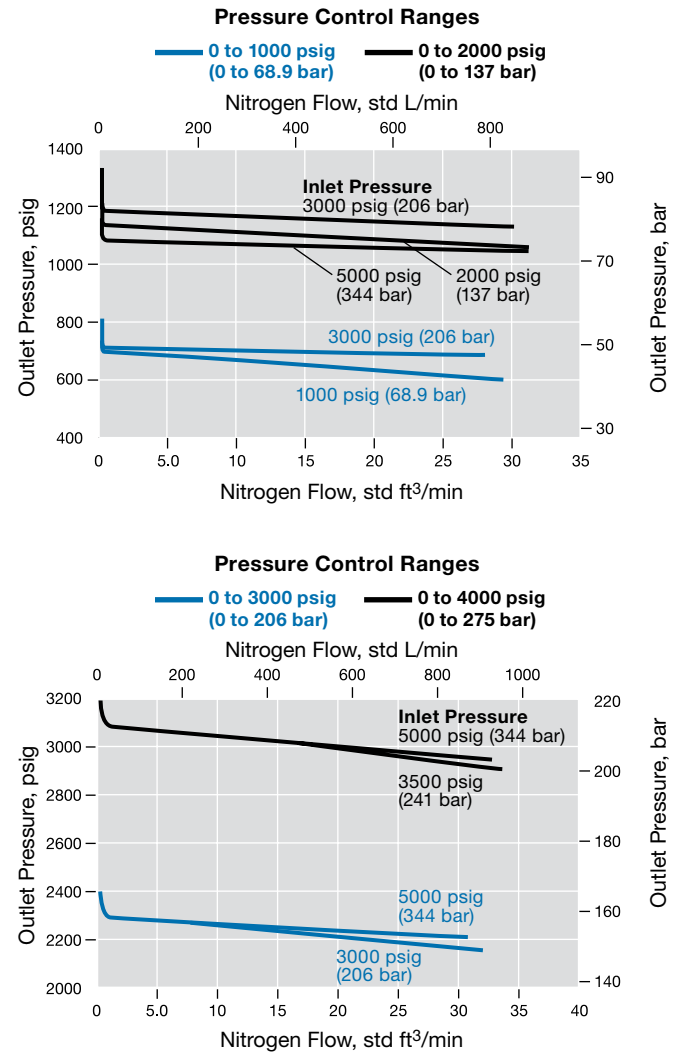

Pressure-Reducing Regulator Flow Data

The graphs illustrate the change or “droop” in outlet pressures as the flow rate increases.

KCP Series

Flow Coefficient 0.06; Maximum Inlet Pressure 3600 psig (248 bar)

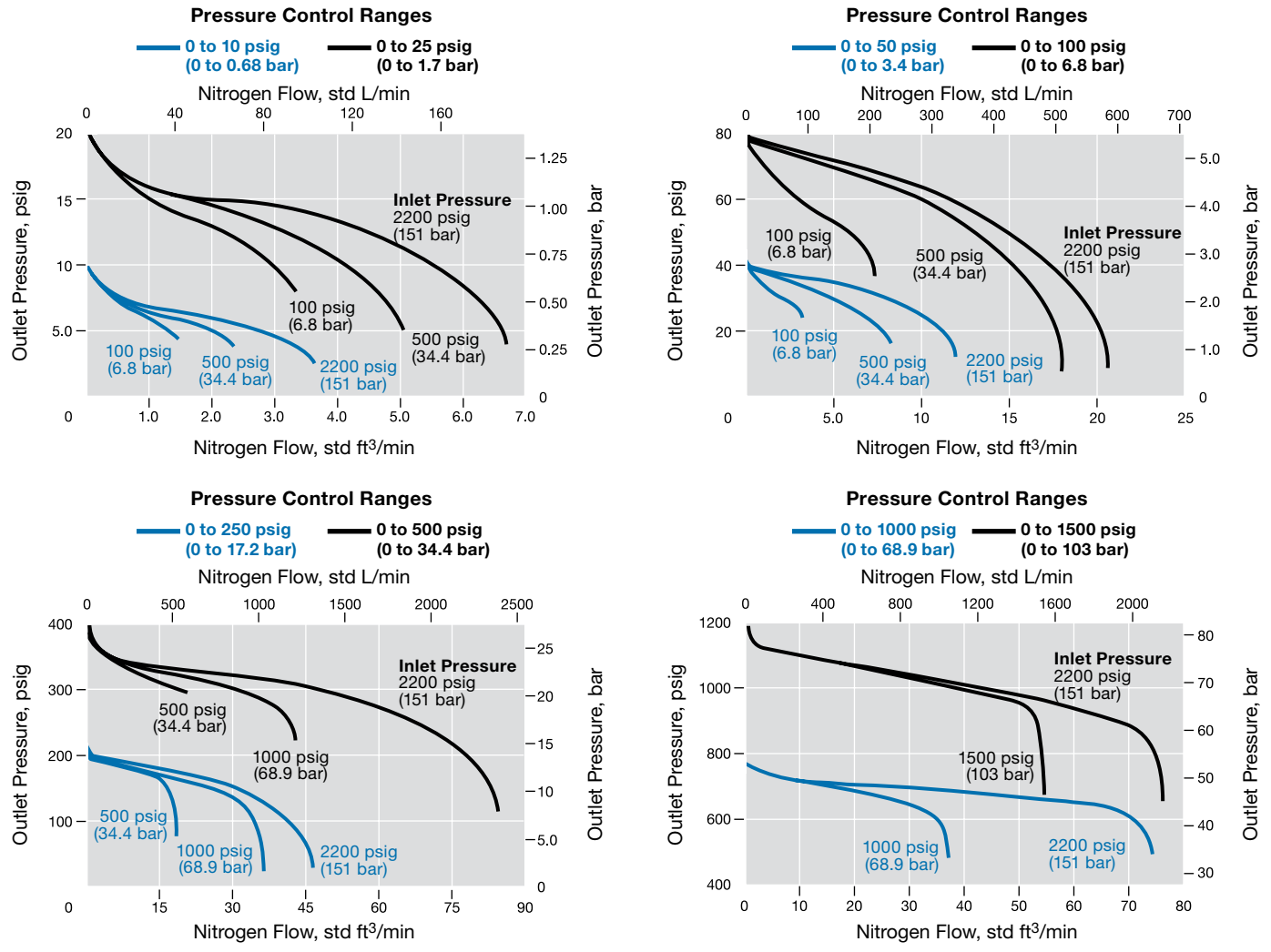

Flow Coefficient 0.20; Maximum Inlet Pressure 3600 psig (248 bar)

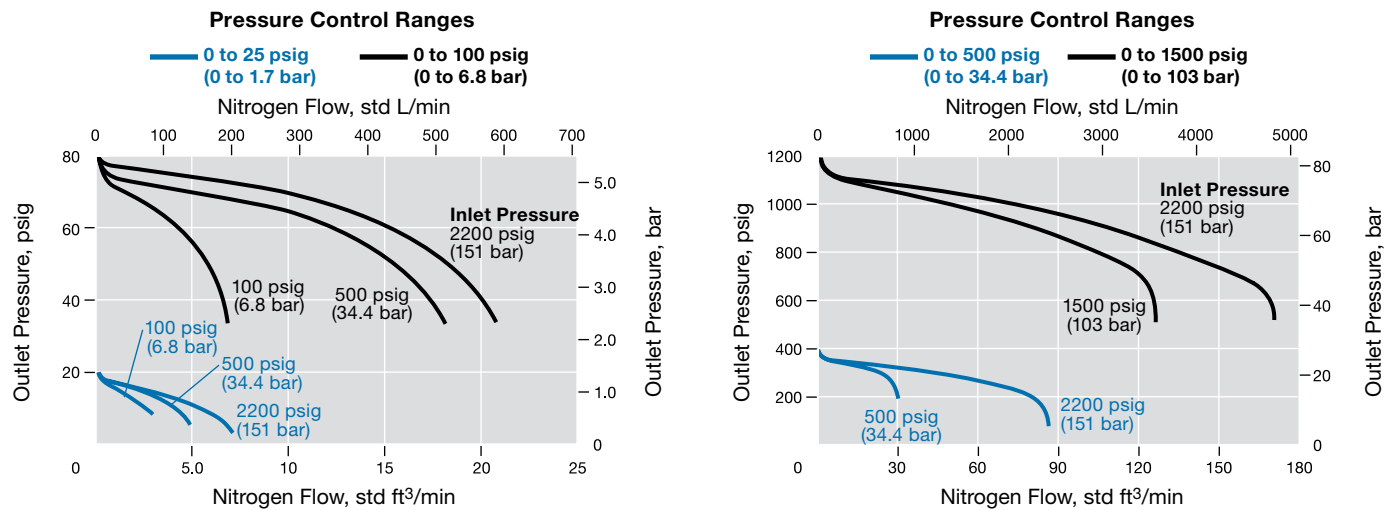

Pressure-Reducing Regulator Flow Data

The graphs illustrate the change or “droop” in outlet pressures as the flow rate increases.

KHP Series

Flow Coefficient 0.06; Maximum Inlet Pressure 10 000 psig (689 bar)

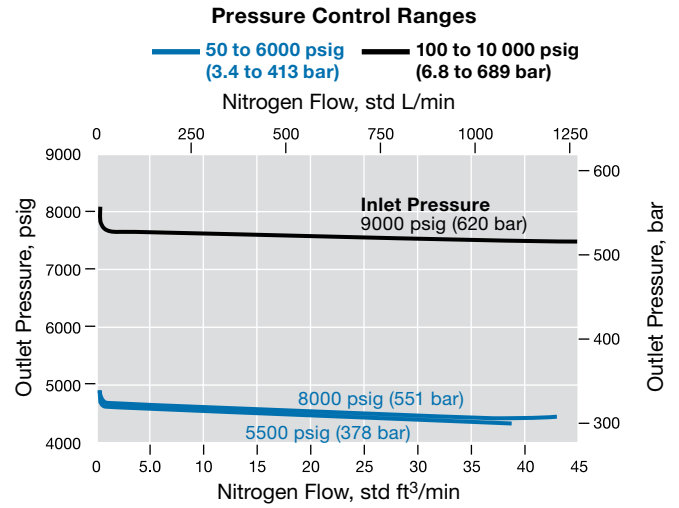
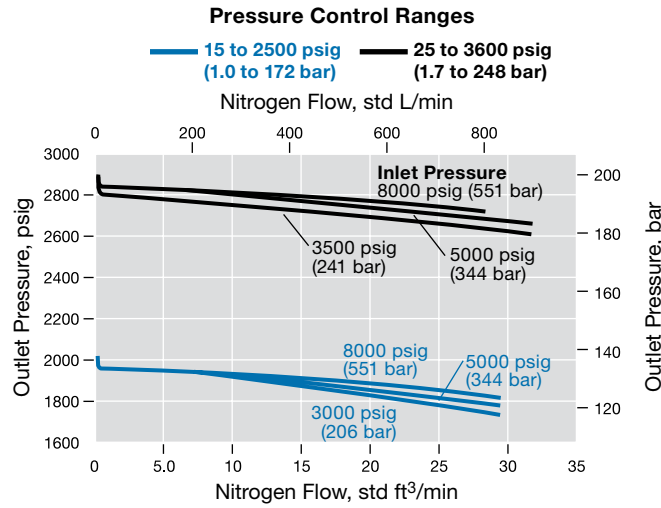
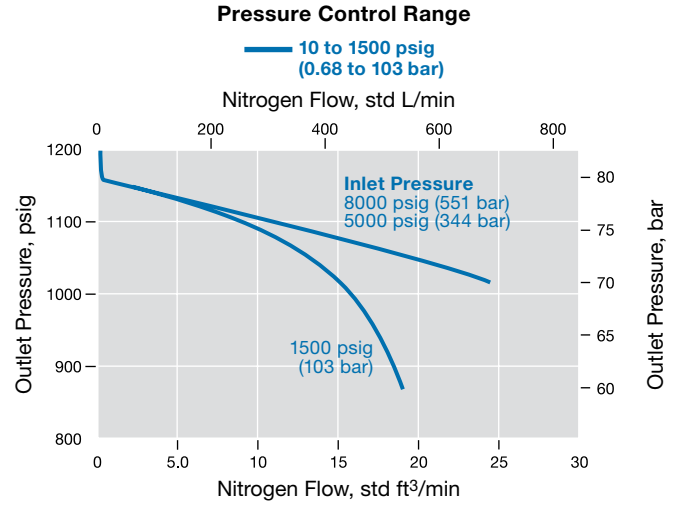
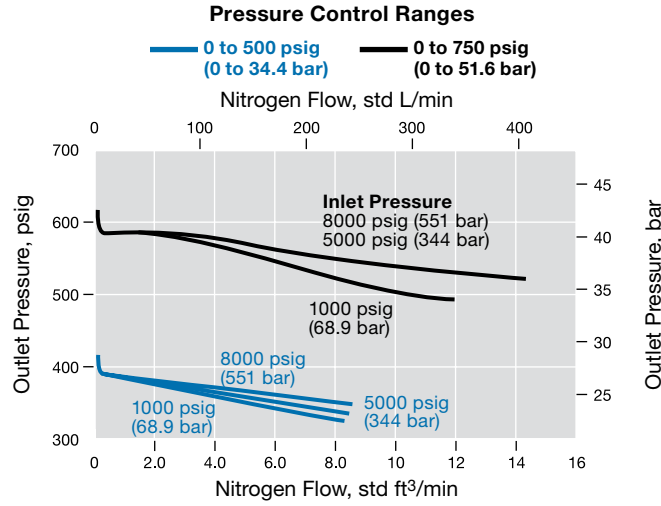

Pressure-Reducing Regulator Flow Data

The graphs illustrate the change or “droop” in outlet pressures as the flow rate increases.

KHP Series

Flow Coefficient 0.25;
Maximum Inlet Pressure 10 000 psig (689 bar)

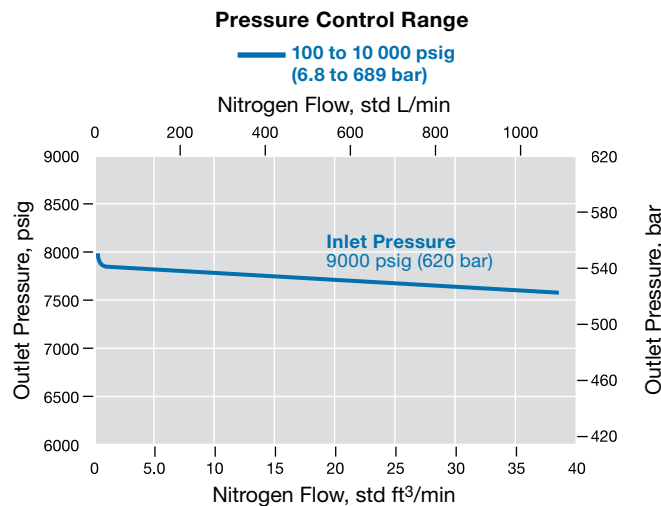
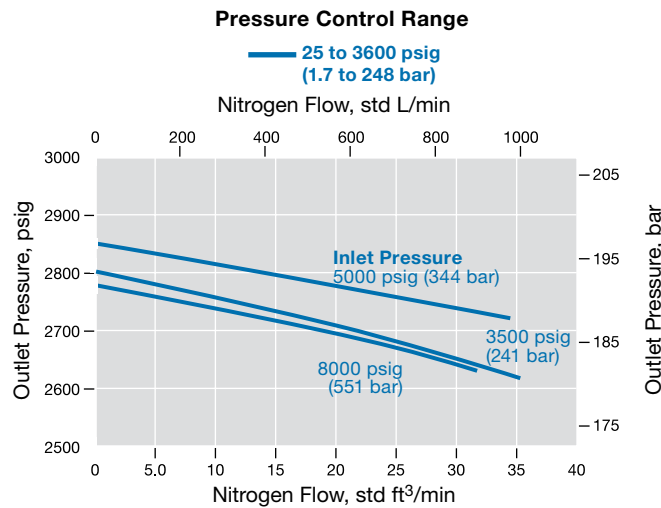
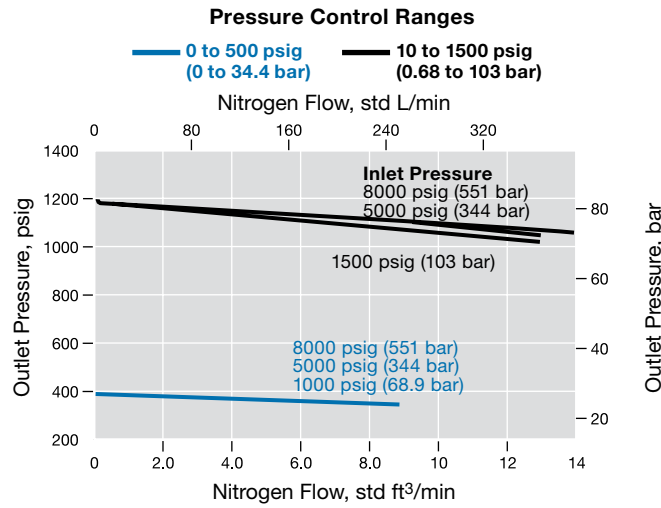

KHR Series

Flow Coefficient 0.06;
Maximum Inlet Pressure 10 000 psig (689 bar)

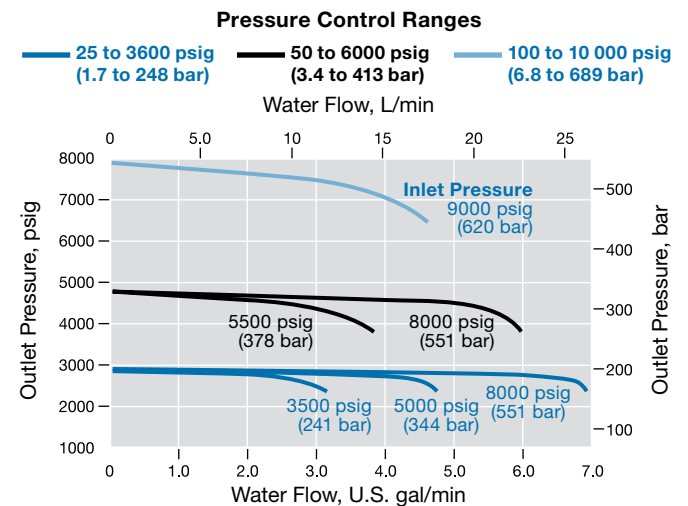
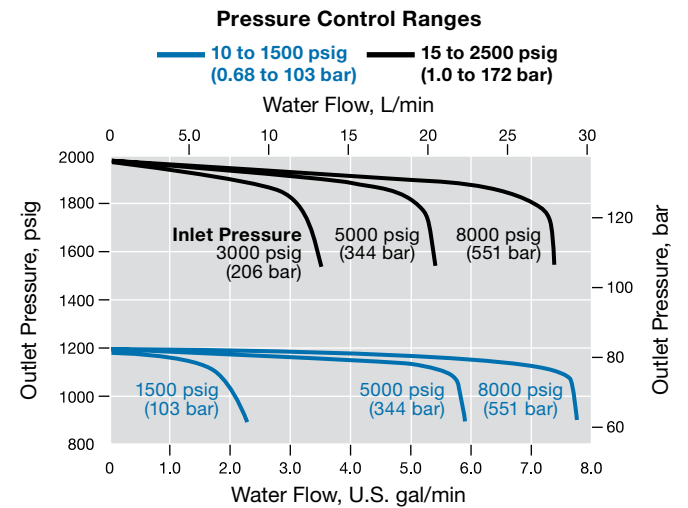
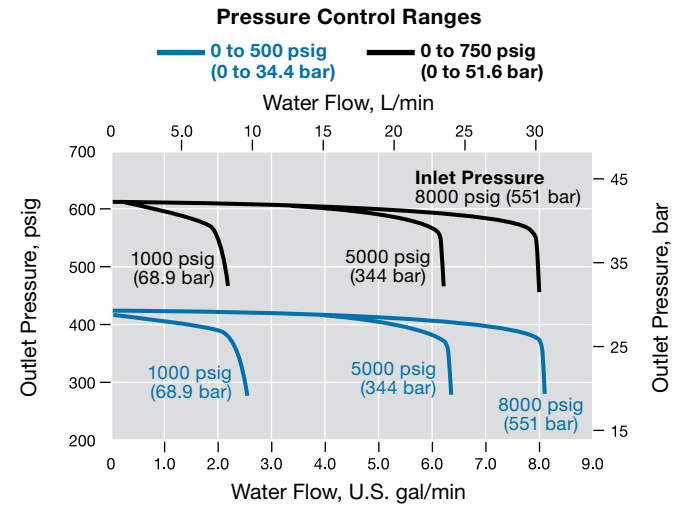

Pressure-Reducing Regulator Flow Data

The graphs illustrate the change or “droop” in outlet pressures as the flow rate increases.

KPP Series

**Flow Coefficient 0.02;
Maximum Inlet Pressure 2000 psig (137 bar)**

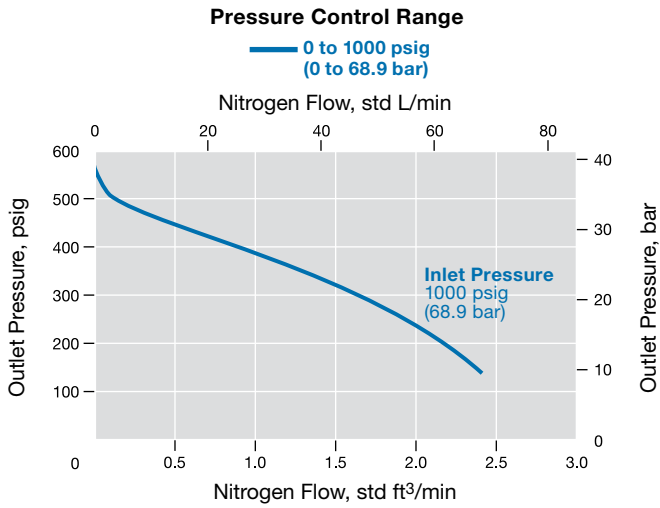

**Flow Coefficient 0.02;
Maximum Inlet Pressure 4000 psig (275 bar)**

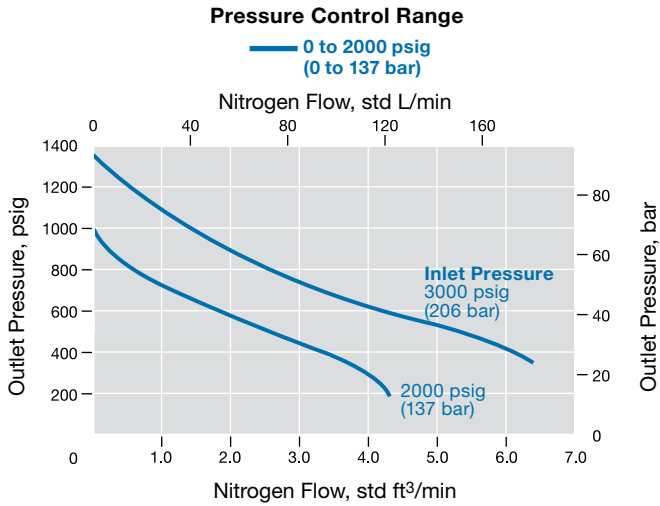

**Flow Coefficient 0.06;
Maximum Inlet Pressure 2000 psig (137 bar)**

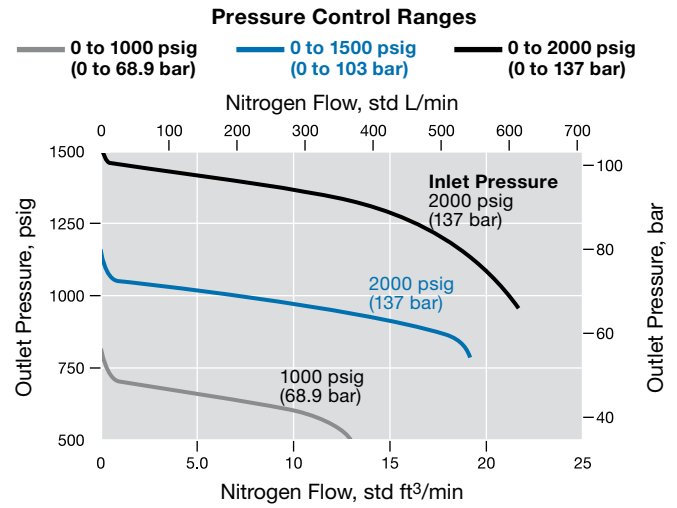

**Flow Coefficient 0.06;
Maximum Inlet Pressure 6000 psig (413 bar)**

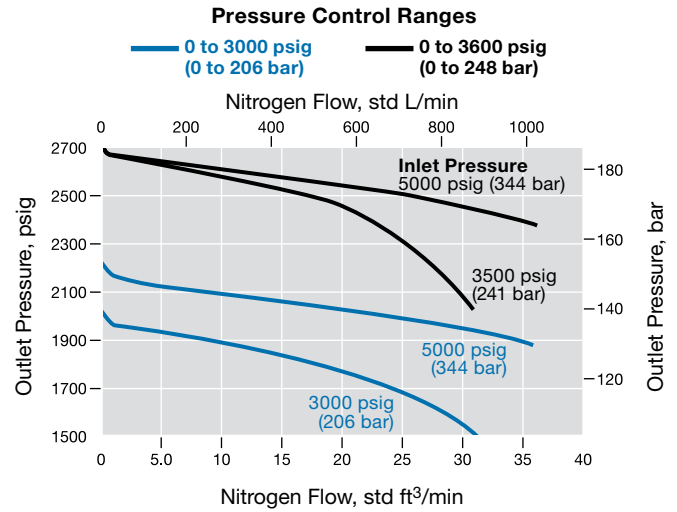

Back-Pressure Regulator Flow Data

The graphs illustrate the change in inlet pressure as the flow rate increases.

KBP Series

Flow Coefficient 0.20

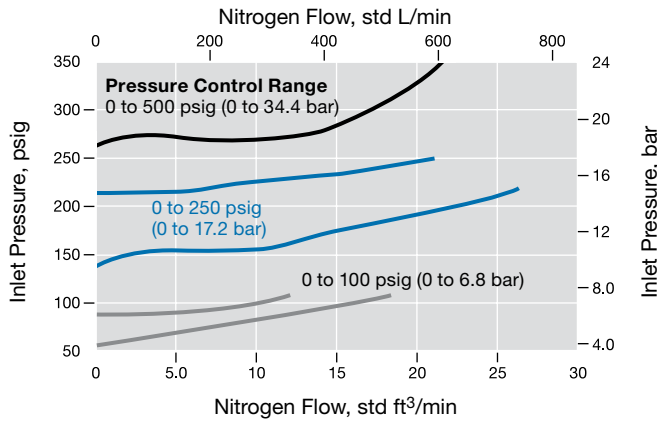

KFB Series

Flow Coefficient 1.0

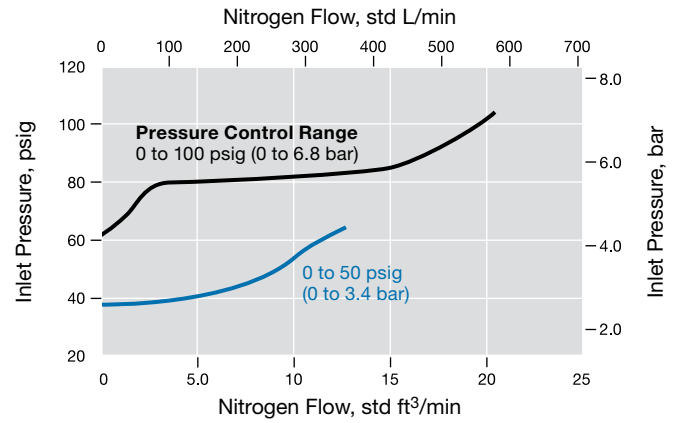

KCB Series

Flow Coefficient 0.20

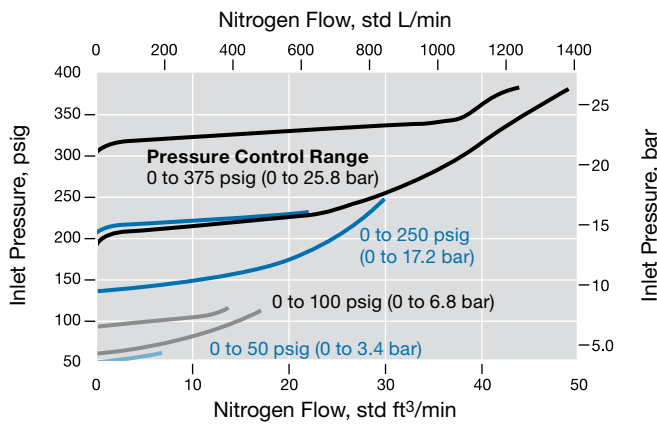

Back-Pressure Regulator Flow Data

The graphs illustrate the change in inlet pressure as the flow rate increases.

KPB Series

Flow Coefficient 0.06

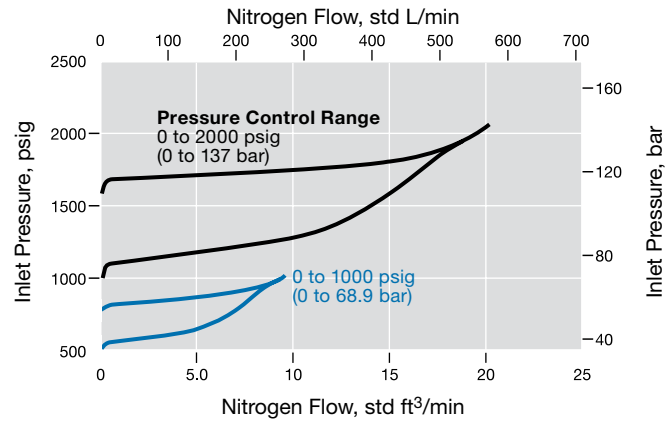

Flow Coefficient 0.20

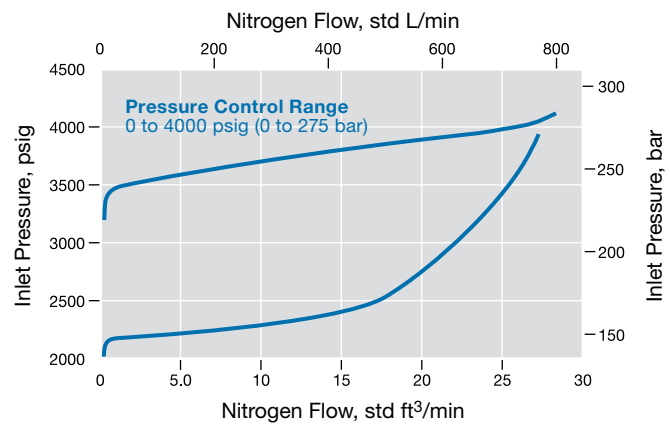
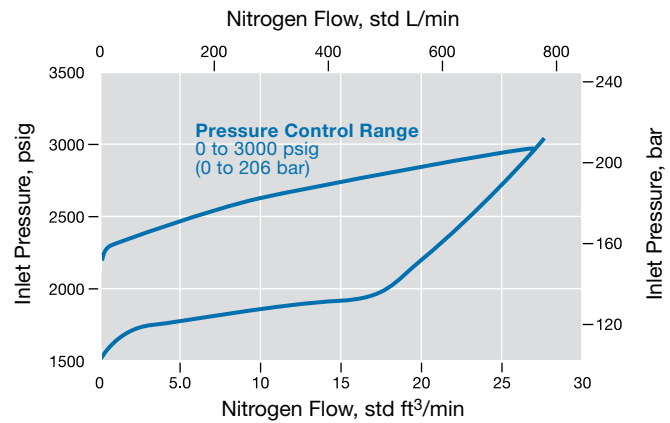
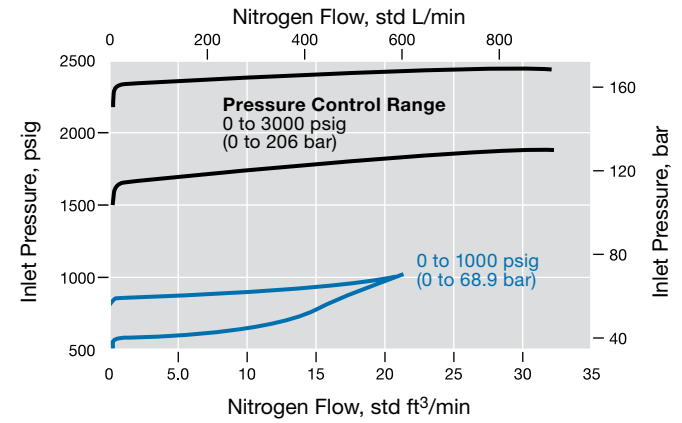

Back-Pressure Regulator Flow Data

The graphs illustrate the change in inlet pressure as the flow rate increases.

KHB Series

Flow Coefficient 0.06

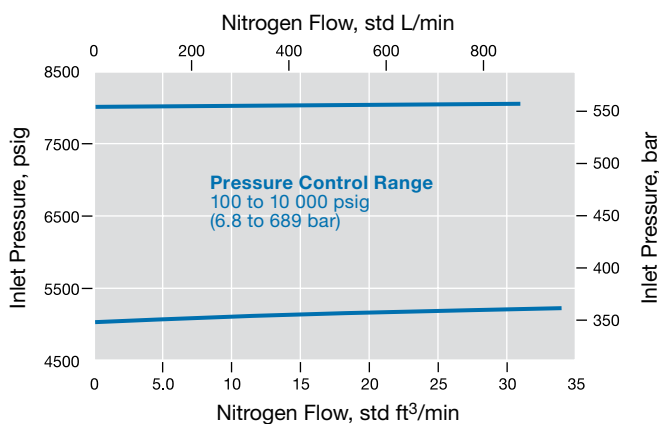
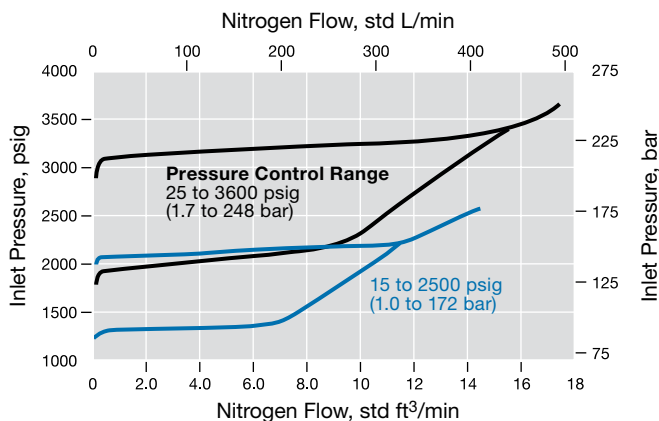
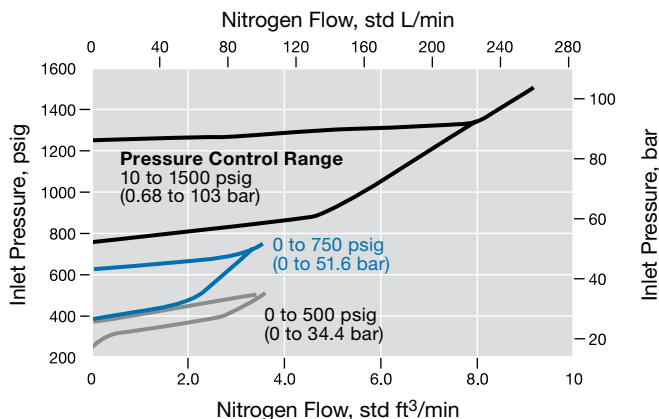

Flow Coefficient 0.25

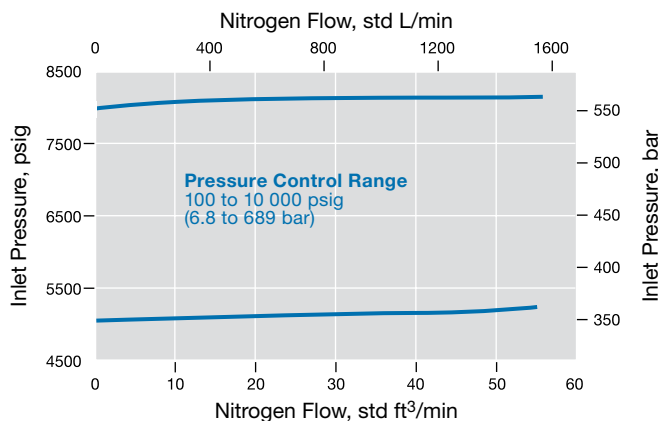
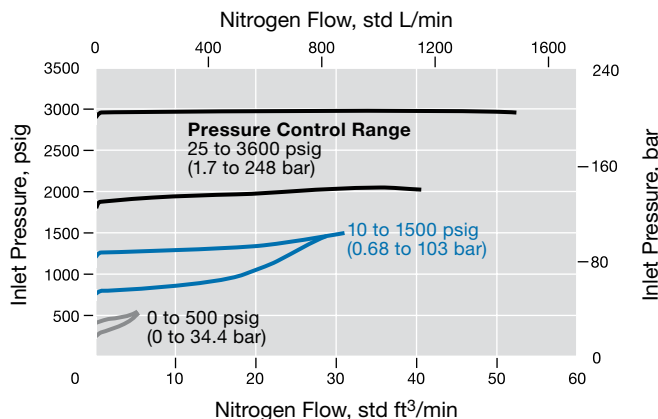

Port Configurations

Port configurations are available as shown in the regulator ordering information pages. The symbols indicate the port location of *factory-assembled* accessories. For alternative accessory locations, contact your authorized Swagelok representative.

Port Configuration Symbols

- Inlet
- Filtered inlet
- Outlet
- G_i Inlet gauge
- G_o Outlet gauge
- R Relief valve
- G_o/R Outlet gauge or relief valve

Factory-assembled *cylinder connections* are placed on a filtered inlet port; *isolation valves* are placed on an outlet port 180° from the cylinder connection.

Select regulators are available on special order with additional port configurations. Contact your authorized Swagelok representative for more information.

Pressure-Reducing Regulators

Right-to-Left Flow

Configuration							
Designator	A	C	E	F	H	L	K

Left-to-Right Flow

Configuration					
Designator	A	B	E	M	N

Back-Pressure Regulators

Right-to-Left Flow

Configuration			
Designator	A	D	V

Left-to-Right Flow

Configuration		
Designator	A	G

MPC Port Configurations

Pressure Reducing

Configuration		
Designator	5	6

Back Pressure

Configuration		
Designator	7	8

Options and Accessories

Regulator accessories are available separately or mounted on Swagelok regulators. Some accessories limit regulator pressure or temperature ratings. Additional materials, options, and accessories are available. Contact your authorized Swagelok representative for more information.



Cylinder Connections

- Available in a variety of CGA connections
- Stainless steel construction

Insert a designator into the ordering number as shown in the appropriate regulator ordering information pages.



Cylinder Gases and Connections

Gas	CGA Connection	Connection Designator
Air, industrial	590	H
Ammonia, anhydrous	660	J
Argon	580	G
Carbon dioxide	320	B
Carbon monoxide	350	D
Chlorine	660	J
Ethane	350	D
Ethylene	350	D
Helium	580	G
Hydrogen	350	D
Hydrogen chloride	330	C
Hydrogen sulfide	330	C
Krypton	580	G
Methane, natural gas	350	D
Methyl chloride	660	J
Methyl mercaptan	330	C
Neon	580	G
Nitric oxide	660	J
Nitrogen	580	G
Nitrogen dioxide	660	J
Oxygen	540	F ^①
Phosgene	660	J
Refrigerant-14	580	G
Refrigerant-22	660	J
Sulfur dioxide	660	J
Sulfur hexafluoride	590	H
Xenon	580	G

① Available only on select KPR and KCY series regulators. Contact your authorized Swagelok representative.

These cylinder connections are rated to 3000 psig (206 bar) maximum, so the maximum inlet pressure designator **P** must be used in the ordering number when a regulator is assembled with a cylinder connection. See the ordering information for each regulator for details.

DIN, BS, and JIS cylinder connections are also available. Contact your authorized Swagelok representative for more information.

Options and Accessories



Pressure Gauges

- Provides measure of inlet pressure, outlet pressure, or both
- 2 1/2 in. (63 mm) dial size with 1/4 in. male NPT connection
- 1 1/2 in. (40 mm) dial size with 1/8 in. male NPT connection
- Stainless steel cases and wetted components



See the Swagelok *Pressure Gauges, Industrial and Process* catalog, MS-02-170, for more information.

Cleaning

Gauges assembled to ASTM G93 Level E or SC-11—cleaned regulators are cleaned in accordance with ASME B40.1 level IV.

Ordering Information

To order a regulator assembled with gauges, insert a designator from the table below into the ordering number as shown in the appropriate regulator ordering information pages. The maximum gauge pressures are appropriate for the maximum inlet pressure and/or control pressure ordered.

Gauge Scale primary unit (secondary unit)	Gauge Designator			Gauge Model ^①
	Inlet and Outlet	Inlet Only	Outlet Only	
psig (bar) (North America only) ^②	1	A	G	C
psig (bar)	3	C	J	B
psig (kPa)	5	E	L	C
bar (psig)	2	B	H	B
MPa	4	D	K	B

^① KCP and KCB series regulators are assembled with M model gauges.

^② Not available for KCP and KCB series regulators.

Isolation Valves

- Allow isolation from downstream equipment
- Working pressures up to 5000 psig (344 bar)
- 316 stainless steel construction
- Swagelok integral-bonnet needle valve (1 series)
- Used in conjunction with an adjustable regulator relief valve



See the Swagelok *Integral-Bonnet Needle Valves* catalog, MS-01-164, for more information.

Isolation Valve and Relief Valve Ordering Information

Isolation valves are available factory assembled on KCP, KPP, KPF, KHP, KHR, and KHB series regulators. Isolation and adjustable regulator relief valves are available factory assembled on KPR, KCY, KCM, KLF, and KHF series regulators.

To order a regulator factory assembled with an isolation valve or isolation valve and adjustable regulator relief valve, insert a designator from the table below into the ordering number as shown in the appropriate regulator ordering information pages.

Description	Valve Designator		
	Relief Only	Isolation Only ^①	Isolation and Relief
Kenmac® KVV series adjustable regulator relief valve	1	—	—
1/4 in. male NPT inlet 1/4 in. Swagelok tube fitting outlet angle pattern isolation valve	—	A	2
1/4 in. male NPT inlet 6 mm Swagelok tube fitting outlet angle pattern isolation valve		B	3
1/4 in. male NPT inlet 1/4 in. female NPT outlet angle pattern isolation valve		C	4
1/4 in. Swagelok tube fitting inlet ^② and outlet straight pattern isolation valve		E	6
6 mm Swagelok tube fitting inlet ^② and outlet straight pattern isolation valve		F	7
3/8 in. Swagelok tube fitting inlet ^② 1/4 in. female NPT outlet straight pattern isolation valve		G	8

^① Not available on KPR, KCY, KCM, KLF, and KHF series regulators, because a relief valve is needed to protect the diaphragm sensing mechanism.

^② Includes male NPT to Swagelok tube adapter fitting (required for regulators with 1/8 and 1/2 in. female NPT ports).

Options and Accessories

Kenmac Adjustable Regulator Relief Valves (KVV Series)

- Provide nonsafety-related pressure protection for Swagelok regulators



Technical Data

Relief Pressure Ranges

- Based on the regulator control range

Regulator Control Range psig (bar)	Relief Pressure Range psig (bar)
0 to 10 (0 to 0.68) 0 to 25 (0 to 1.7) 0 to 50 (0 to 3.4)	0 to 100 (0 to 6.8)
0 to 100 (0 to 6.8)	50 to 200 (3.4 to 13.7)
0 to 250 (0 to 17.2) 0 to 500 (0 to 34.4)	150 to 500 (10.3 to 34.4)

Maximum Operating Temperature

- 392°F (200°C)

Weight

- 0.26 lb (0.12 kg)

Ports

- 1/4 in. NPT male inlet and female outlet

Materials of Construction

Component	Material
<i>Body, poppet, spring button, adjusting screw</i>	316 SS
<i>Seal</i>	Fluorocarbon FKM
<i>Range spring</i>	302 SS

Wetted components listed in *italics*.

Testing

Every KVV series regulator relief valve is factory tested at its maximum rated pressure, then set to zero when assembled to the regulator.

- ⚠ **Reset relief pressure to the desired value before pressurizing the system.**

Flow Data

The graph illustrates the discharge characteristics of the Kenmac adjustable regulator relief valve.

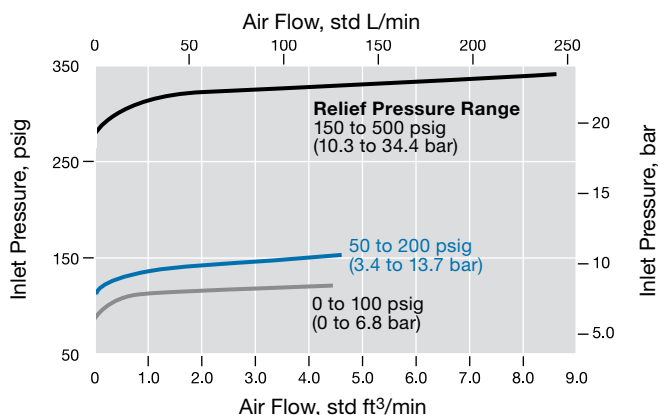

Ordering Information

To order a KVV adjustable regulator relief valve separately, select an ordering number from the table below.

Relief Pressure Range psig (bar)	Ordering Number
0 to 100 (0 to 6.8)	KVV11DE1
50 to 200 (3.4 to 13.7)	KVV11DG1
150 to 500 (10.3 to 34.4)	KVV11DI1

- ⚠ **For valves not actuated for a period of time, initial relief pressure may be higher than the set pressure.**
- ⚠ **Kenmac adjustable regulator relief valves are not “safety accessories” as defined in the Pressure Equipment Directive 97/23/EC.**
- ⚠ **Some system applications require relief valves to meet specific safety codes. The system designer and user must determine when such codes apply and whether these relief valves conform to them.**

Options and Accessories

Hoses

Hoses are available assembled to the inlet of the regulator to allow connection to remote gas cylinders.

Hose options, rated to 3000 psig (206 bar), include:

- 3 ft long Swagelok 1/4 in. high-pressure, metal flexible hose (FM series), 1/4 in. female NPT inlet, 1/4 in. male NPT outlet connected to regulator: SS-FM4PM4PF4-36
- 3 ft long Swagelok 1/4 in. PTFE-lined, stainless steel braided hose (TH series), 1/4 in. female NPT inlet, 1/4 in. male NPT outlet connected to regulator: SS-TH4PM4PF4-36



See the **Swagelok Hose and Flexible Tubing catalog, MS-01-180**, for more information.

Cleaning

Hoses are not available assembled to ASTM G93 Level E or SC-11 specially-cleaned regulators.

Handles

Knob, thumbwheel, and antitamper handles are available.

The green plastic knob handle is standard for most Swagelok regulators. Other colors are available; add a handle color designator to a regulator ordering number.

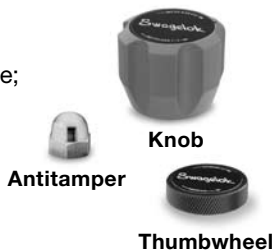

Color	Designator
Black	BK
Blue	BL
Orange	OR
Red	RD
Yellow	YW

Example: KPR1FRF412A20000**BK**

The metal thumbwheel handle is available for the compact KCB and KCP series regulators.

The metal antitamper nut is available to prevent inadvertent pressure adjustment.

Wall Mounting Brackets

Stainless steel wall mounting brackets are available for many Swagelok regulators.

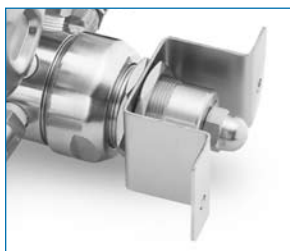

**KCY Series
Mounting Bracket**

Requires 1st stage panel-mount option. See page 9.



**KPR, KLF, KHF, KCP, KPP,
KPF, KHP, KBP, KFB, KCB,
KP, and KHB Series
Mounting Bracket**

Wall Mounting Bracket Kits

Regulator Series	Ordering Number
KPR, KLF, KHF, KCP, KPP, KPF, KHP, KBP, KFB, KCB, KP, KHB	9R0079
KCY	9R0149

Maintenance Kits

Filter Replacement Kits

Filter replacement kits are available for KPR, KCM, KCP, KCY, KPP, KHP, KLF, KHR, KHF, and KPF series regulators.

Filter replacement kits include:

- five sets of filters, filter rings, and filter retaining rings
- instructions.

Regulator Series	Inlet Size	Ordering Number
KCP	1/8 in. NPT	REG-FILTER-2-KIT5
KPR, KCM, KCY, KPP, KHP, KLF, KHR	1/4 in. NPT	REG-FILTER-4-KIT5
KHF, KPF	1/2 in. NPT	REG-FILTER-8-KIT5

KPR, KCP, AND KBP Series Maintenance Kits

Maintenance kits include:

- all wetted components, except for the regulator body and piston, if applicable
- wetted lubricant with MSDS
- instructions.

KCY series regulators can be rebuilt with two KPR series maintenance kits.

- The second-stage kit should be configured for the desired pressure control range.
- The first-stage kit should specify designator **J** for the pressure control range and designator **0** for the ports (filter size). All other options should match those of the second-stage kit.

Ordering Information

Build a maintenance kit ordering number by combining the designators in the sequence shown below.

1 2 3 **4** **5** **6** **7** **8** **9** **10** **11** **12** **13 14 15 16**
K P R 1 D 0 0 4 1 2 A 0 - K I T

1 2 3 Regulator Series

KPR = KPR
KCP = KCP
KBP = KBP

4 Body Material, Cleaning

1 = 316 SS and brass
C = 316 SS and brass, SC-11 cleaned

5 Pressure Control Range

KPR and KBP Series

D = 0 to 10 psig (0 to 0.68 bar) and 0 to 25 psig (0 to 1.7 bar)
F = 0 to 50 psig (0 to 3.4 bar) and 0 to 100 psig (0 to 6.8 bar)
J = 0 to 250 psig (0 to 17.2 bar) and 0 to 500 psig (0 to 34.4 bar)

KCP Series

G = 0 to 10 psig (0 to 0.68 bar), 0 to 25 psig (0 to 1.7 bar), 0 to 50 psig (0 to 3.4 bar), 0 to 100 psig (0 to 6.8 bar), and 0 to 250 psig (0 to 17.2 bar)
M = 0 to 500 psig (0 to 34.4 bar), 0 to 1000 psig (0 to 68.9 bar), and 0 to 1500 psig (0 to 103 bar)^①

^① Not available with MPC platform port configuration.

6 Maximum Inlet Pressure

0 = Not applicable

7 Port Configuration

0 = Not applicable

8 Ports (Filter Size)

KPR Series

4 = 1/4 in. female NPT
0 = All other end connections

KBP Series

0 = Not applicable

KCP Series

2 = 1/8 in. female NPT
M = MPC platform

9 Seat, Seal Material

KPR Series

1 = PCTFE
2 = PEEK

KBP and KCP Series

A = Fluorocarbon FKM, PCTFE
B = Kalrez, PCTFE
C = Fluorocarbon FKM, PEEK
D = Kalrez, PEEK

10 Flow Coefficient (C_v)

1 = 0.02
2 = 0.06
5 = 0.20^{①②}
7 = 0.50^①

^① Not available with MPC platform port configuration.

^② Required for KBP series.

11 Sensing Mechanism, Vent

KPR Series

A = Alloy X-750 diaphragm, no-vent models and captured-vent models
C = Alloy X-750 diaphragm, self-vent models and self- and captured-vent models

KBP Series

A = Alloy X-750 diaphragm, all models

KCP Series

P = 316 SS piston

12 Handle, Mounting

0 = Not applicable

Additional Products

Filters

Swagelok offers a variety of filters, filter elements, and sizes.

- 316 SS and brass materials
- Sintered and strainer elements
- Tee type, inline, and all-welded models

For more information about Swagelok filters, see the *Filters—FW, F, and TF Series* catalog, MS-01-92.



Transducers

Swagelok industrial pressure transducers electronically monitor fluid system pressure in a variety of analytical and process applications.

- Accurate and repeatable readings
- Swagelok tube adapter end connections available for ease of installation and maintenance
- CE compliant

For more information about Swagelok industrial pressure transducers, see the *Industrial Pressure Transducers* catalog, MS-02-225.



⚠ Swagelok pressure regulators are not “Safety Accessories” as defined in the Pressure Equipment Directive 97/23/EC.

⚠ Do not use the regulator as a shutoff device.

Safe Product Selection

When selecting a product, the total system design must be considered to ensure safe, trouble-free performance. Function, material compatibility, adequate ratings, proper installation, operation, and maintenance are the responsibilities of the system designer and user.

Caution: Do not mix or interchange parts with those of other manufacturers.

Warranty Information

Swagelok products are backed by The Swagelok Limited Lifetime Warranty. For a copy, visit swagelok.com or contact your authorized Swagelok representative.

Swagelok, Kenmac, VCR—TM Swagelok Company
Elgiloy—TM Elgiloy Limited Partnership
Kalrez—TM DuPont
© 2005–2010 Swagelok Company
Printed in U.S.A., AGS
March 2010, R5
MS-02-230